



# SolarEdge

## Installation Guide

For Europe, APAC, Australia & South Africa

Version 3.3

# Disclaimers

## Important Notice

---

Copyright © SolarEdge Inc. All rights reserved.

No part of this document may be reproduced, stored in a retrieval system or transmitted, in any form or by any means, electronic, mechanical, photographic, magnetic or otherwise, without the prior written permission of SolarEdge Inc.

The material furnished in this document is believed to be accurate and reliable. However, SolarEdge assumes no responsibility for the use of this material. SolarEdge reserves the right to make changes to the material at any time and without notice. You may refer to the SolarEdge web site ([www.solaredge.com](http://www.solaredge.com)) for the most updated version.

All company and brand products and service names are trademarks or registered trademarks of their respective holders.

Patent marking notice: see <http://www.solaredge.com/patent>

The general terms and conditions of delivery of SolarEdge shall apply.

The content of these documents is continually reviewed and amended, where necessary. However, discrepancies cannot be excluded. No guarantee is made for the completeness of these documents.

The images contained in this document are for illustrative purposes only and may vary depending on product models.

## Emission Compliance

---

This equipment has been tested and found to comply with the limits applied by the local regulations. These limits are designed to provide reasonable protection against harmful interference in a residential installation. This equipment generates, uses and can radiate radio frequency energy and, if not installed and used in accordance with the instructions, may cause harmful interference to radio communications. However, there is no guarantee that interference will not occur in a particular installation. If this equipment does cause harmful interference to radio or television reception, which can be determined by turning the equipment off and on, you are encouraged to try to correct the interference by one or more of the following measures:

- Reorient or relocate the receiving antenna.
- Increase the separation between the equipment and the receiver.
- Connect the equipment into an outlet on a circuit different from that to which the receiver is connected.
- Consult the dealer or an experienced radio/TV technician for help.

Changes or modifications not expressly approved by the party responsible for compliance may void the user's authority to operate the equipment.

# Support and Contact Information

If you have technical problems concerning SolarEdge products, please contact us:

Country	Phone	E-Mail
Australia (+61)	1800 465 567	<a href="mailto:support@solaredge.net.au">support@solaredge.net.au</a>
APAC (Asia Pacific)(+972)	073 240 3118	<a href="mailto:support-asia@solaredge.com">support-asia@solaredge.com</a>
China (+86)	21 6212 5536	<a href="mailto:support_china@solaredge.com">support_china@solaredge.com</a>
DACH & Rest of Europe (+49)	089 454 59730	<a href="mailto:support@solaredge.de">support@solaredge.de</a>
France and Belgium (+33)	0800 917410	<a href="mailto:support@solaredge.fr">support@solaredge.fr</a>
Italy (+39)	0422 053700	<a href="mailto:support@solaredge.it">support@solaredge.it</a>
Japan (+81)	03 5530 9360	<a href="mailto:support@solaredge.jp">support@solaredge.jp</a>
Netherlands (+31)	0800 0221 089	<a href="mailto:support@solaredge.nl">support@solaredge.nl</a>
New Zealand (+64)	0800 144 875	<a href="mailto:support@solaredge.net.au">support@solaredge.net.au</a>
US & Canada (+1)	510 498 3200	<a href="mailto:ussupport@solaredge.com">ussupport@solaredge.com</a>
United Kingdom (+44)	0800 028 1183	<a href="mailto:support-uk@solaredge.com">support-uk@solaredge.com</a>
Greece (+30)	0800 125574	<a href="mailto:support@solaredge.com">support@solaredge.com</a>
Middle East & Africa (+972)	073 240 3118	
South Africa (+27)	0800 982 659	
Turkey (+972)	073 240 3118	
Worldwide (+972)	073 240 3118	

Before contact, make sure to have the following information at hand:

- Model and serial number of the product in question.
- The error indicated on the inverter screen or on the SolarEdge monitoring platform, if there is such an indication.
- System configuration information, including the type and number of modems connected and the number and length of strings.
- The communication method to the SolarEdge server, if the site is connected.
- The inverter software version as appears in the ID status screen (see *ID Status* on page 42).

# Contents

<b>Disclaimers</b> .....	<b>1</b>
Important Notice .....	1
Emission Compliance .....	1
<b>Support and Contact Information</b> .....	<b>2</b>
<b>Contents</b> .....	<b>3</b>
<b>HANDLING AND SAFETY INSTRUCTIONS</b> .....	<b>6</b>
Safety Information .....	6
<b>IMPORTANT SAFETY INSTRUCTIONS</b> .....	<b>7</b>
<b>Chapter 1: Introducing the SolarEdge Power Harvesting System</b> .....	<b>9</b>
SolarEdge Power Optimizer .....	9
SolarEdge Inverter .....	9
SolarEdge Monitoring Platform .....	9
Installation Procedure .....	10
Installation Equipment List .....	10
Inverter Transport and Storage .....	10
<b>Chapter 2: Installing the Power Optimizers</b> .....	<b>11</b>
Safety .....	11
Installation Guidelines .....	11
Step 1: Mounting the Power Optimizers .....	12
Step 2: Connecting a PV Module to a Power Optimizer .....	13
Step 3: Connecting Power Optimizers in Strings .....	13
Step 4: Verifying Proper Power Optimizer Connection .....	14
<b>Chapter 3: Installing the Inverter</b> .....	<b>15</b>
Inverter Package Contents .....	15
Identifying the Inverter .....	15
Inverter Interfaces .....	15
Mounting the Inverter .....	17
<b>Chapter 4: Connecting the AC and the Strings to the Inverter</b> .....	<b>21</b>
Grid Connection Guidelines .....	21
Connecting the AC Grid to the Inverter .....	21
Connecting the Strings to the Inverter .....	23
Selecting a Residual Current Device (RCD) .....	23
Demand Response Enabling Device (DRED) .....	24
<b>Chapter 5: Commissioning the Installation</b> .....	<b>25</b>
Step 1: Activating the System .....	25
Step 2: Pairing Power Optimizers to the Inverter .....	27
Step 3: Verifying Proper Activation .....	28
Step 4: Reporting and Monitoring Installation Data .....	29
The SolarEdge Monitoring System .....	29
Providing Installation Information .....	30
Site Mapper Application .....	30
Creating a Site in the SolarEdge Monitoring Platform .....	30
Paper Template .....	30

<b>Chapter 6: User Interface</b> .....	<b>31</b>
LCD User Buttons .....	31
Inverter Configuration – Setup Mode .....	31
Configuring the Inverter Using the Internal LCD User Buttons .....	32
Configuring the Inverter Using the LCD Light Button .....	34
Configuration Menu Options .....	36
Country and Grid .....	36
Language .....	36
Communication .....	36
Power Control .....	38
Display .....	39
Maintenance .....	39
Information .....	39
Status Screens - Operational Mode .....	40
Initial Status .....	40
Main Inverter Status .....	40
Energy Meter Status .....	41
Telemetry Status .....	41
ID Status .....	42
Server Communication Status .....	42
IP Status .....	43
ZigBee Status .....	43
Wi-Fi Status .....	43
GSM Status .....	43
Communication Ports Status .....	44
Smart Energy Management Status .....	44
Fan Status .....	45
Power Control Status .....	45
<b>Chapter 7: Setting Up Communication</b> .....	<b>47</b>
Communication Options .....	47
Ethernet .....	47
RS485 .....	47
ZigBee .....	47
Wi-Fi .....	47
GSM .....	48
Communication Connectors .....	48
Removing the Inverter Cover .....	49
Creating an Ethernet (LAN) Connection .....	49
Creating an RS485 Bus Connection .....	51
Verifying the Connection .....	55
<b>Appendix A: Errors and Troubleshooting</b> .....	<b>56</b>
Troubleshooting Communication .....	56
Troubleshooting Ethernet Communication .....	56
Additional Troubleshooting .....	57
Power Optimizer Troubleshooting .....	58

---

<b>Appendix B: Mechanical Specifications</b> .....	<b>59</b>
Single Phase Inverter and Mounting Bracket .....	59
Three Phase Inverter and Mounting Bracket .....	60
<b>Appendix C: Connecting the AC and DC Strings to the DC Safety Unit</b> .....	<b>61</b>
Connecting the AC Grid to the Inverter .....	62
Connecting the Strings to the DC Safety Unit .....	63
<b>Appendix D: SafeDC™</b> .....	<b>65</b>
<b>Appendix E: External Fan Maintenance and Replacement</b> .....	<b>66</b>
Fan Maintenance .....	66
External Fan Replacement .....	66
<b>Appendix F: Replacing and Adding System Components</b> .....	<b>68</b>
Replacing an Inverter .....	68
Replacing the DC Safety Unit .....	69
Removing the DC Safety Unit .....	69
Installing a New DC Safety Unit .....	69
Connecting the Safety Switch to the Inverter .....	69
Adding, Removing, or Replacing Power Optimizers .....	72
<b>Technical Specification Documents:</b> .....	<b>74</b>
Single Phase Inverters	
Three Phase Inverters	
Three Phase E-Series Inverters - SE4k-SE8k	

# HANDLING AND SAFETY INSTRUCTIONS

During installation, testing and inspection, adherence to all the handling and safety instructions is mandatory. **Failure to do so may result in injury or loss of life and damage to the equipment.**

## Safety Information

The following safety symbols are used in this document. Familiarize yourself with the symbols and their meaning before installing or operating the system.

### WARNING!



Denotes a hazard. It calls attention to a procedure that, if not correctly performed or adhered to, could result in **injury or loss of life**. Do not proceed beyond a warning note until the indicated conditions are fully understood and met.

### CAUTION!



Denotes a hazard. It calls attention to a procedure that, if not correctly performed or adhered to, could result in **damage or destruction of the product**. Do not proceed beyond a caution sign until the indicated conditions are fully understood and met.

### NOTE



Denotes additional information about the current subject.

### IMPORTANT SAFETY FEATURE



Denotes information about safety issues.

Disposal requirements under the Waste Electrical and Electronic Equipment (WEEE) regulations:



### NOTE

Discard this product according to local regulations or send it back to SolarEdge.

# IMPORTANT SAFETY INSTRUCTIONS

SAVE THESE INSTRUCTIONS

## WARNING!



The inverter cover must be opened only after shutting off the inverter ON/OFF switch located at the bottom of the inverter. This disables the DC voltage inside the inverter. Wait five minutes before opening the cover. Otherwise, there is a risk of electric shock from energy stored in the capacitors.



## WARNING



Before operating the inverter, ensure that the inverter AC power cable and wall outlet are grounded properly.

## WARNING



Opening the inverter and repairing or testing under power must be performed only by qualified service personnel familiar with this inverter.

## WARNING!



Do not touch the PV panels or any rail system connected when the inverter switch is ON, unless grounded.

## WARNING!



SafeDC complies with IEC60947-3 when installing the system with a worst case SafeDC voltage (under fault conditions)  $< 120V$ .

The worst case voltage is defined as:  $V_{oc,max} + (\text{String Length} - 1) * 1V$ , where:

- $V_{oc,max}$  = Maximum  $V_{oc}$  (at lowest temperature) of the PV module in the string (for a string with multiple module models, use the max value)
- String Length = number of power optimizers in the string

## CAUTION!



This unit must be operated under the specified operating specifications, as described in the latest technical specification datasheet provided with the unit.

## NOTE



The inverter is IP65 rated. Unused conduit openings and glands should be sealed with appropriate seals.

## CAUTION!



**HEAVY OBJECT.** To avoid muscle strain or back injury, use proper lifting techniques, and if required - a lifting aid when removing or replacing.

## NOTE



Use PV modules rated according to IEC 61730 class A.

## NOTE



The symbol  appears at grounding points on the SolarEdge equipment. This symbol is also used in this manual.



**NOTE**

The following warning symbols appear on the inverter warning label:



Risk of electric shock



**5 Minutes**

Risk of electric shock from energy stored in the capacitor. Do not remove cover until 5 minutes after disconnecting all sources of supply.



Hot surface – To reduce the risk of burns, do not touch.

# Chapter 1: Introducing the SolarEdge Power Harvesting System

The SolarEdge power harvesting solution maximizes the power output from any type of solar Photovoltaic (PV) installation while reducing the average cost per watt. The following sections describe each of the system's components.

## SolarEdge Power Optimizer

---

The SolarEdge power optimizers are DC-DC converters connected to PV modules in order to maximize power harvesting by performing independent Maximum Power Point Tracking (MPPT) at the module level.

The power optimizers regulate the string voltage at a constant level, regardless of string length and environmental conditions.

The power optimizers include a safety voltage function that automatically reduces the output of each power optimizer to 1 Vdc in the following cases:

- During fault conditions
- The power optimizers are disconnected from the inverter
- The inverter's ON/OFF switch is turned OFF

Each power optimizer also transmits module performance data over the DC power line to the inverter.

Two types of power optimizers are available:

- Module Add-on power optimizer – connected to one or more modules
- Smart modules - the power optimizers are embedded into a module

## SolarEdge Inverter

---

The SolarEdge inverter efficiently converts DC power from the modules into AC power that can be fed into the main AC service of the site and from there to the grid. The inverter also receives the monitoring data from each power optimizer and transmits it to a central server (the SolarEdge monitoring platform; requires Internet connection).

Some inverters are available with an optional DC Safety Unit. The DC Safety Unit is a manually operated switch for disconnecting the DC power of a SolarEdge system.

The DC Safety Unit is located below the inverter and is connected to the inverter with AC and DC wires.

## SolarEdge Monitoring Platform

---

The SolarEdge monitoring platform enables monitoring the technical and financial performance of one or more SolarEdge sites. It provides past and present information on the system performance both at the system and module levels.

## Installation Procedure

---

The following is the procedure for installing and setting up a new SolarEdge site. Many of these also apply to modification of an existing site.

1. [Connecting Power Optimizers in Strings](#), page 13
2. [Recording power optimizer serial numbers \(optional\)](#), page 30
3. [Mounting the inverter](#), page 17
4. [Connecting the AC and the Strings to the Inverter](#), page 21, or [Connecting the AC and the String to the DC Safety Unit](#), page 62.
5. [Commissioning and activating the installation](#), page 25.
6. [Connecting the inverter to the SolarEdge monitoring platform](#), page 30.
7. [Configuring the inverter](#), page 31.

## Installation Equipment List

---

Standard tools can be used during the installation of the SolarEdge system. The following is a recommendation of the equipment needed for installation:

- Allen screwdriver for 5mm screw type for the inverter cover, DC Safety Unit cover (if applicable), and inverter side screws
- Allen screwdriver for M5/M6/M8 screw types
- Standard flat-head screwdrivers set
- Non-contact voltage detector
- Cordless drill or screwdriver and bits suitable for the surface on which the inverter will be installed
- Suitable hardware for attaching the inverter mounting bracket to the surface to which it will be connected
- M6 (1/4") or M8 (5/16") stainless bolts, nuts, and washers for attaching the power optimizer to the racking (not required for smart modules)
- MC4 crimper
- Wire cutters
- Wire strippers
- Voltmeter

For installing the communication options, you may also need the following:

- For Ethernet:
  - CAT5/6 twisted pair Ethernet cable with RJ45 connector.
  - If using a CAT5/6 cable spool: RJ45 plug and RJ45 crimper
- For RS485:
  - Four- or six-wire shielded twisted pair cable.
  - Watchmaker precision screwdriver set

## Inverter Transport and Storage

---

Transport the inverter in its original packaging, facing up and without exposing it to unnecessary shocks. If the original package is no longer available, use a similar box that can withstand the weight of the inverter (refer to the inverter weight in the specification datasheet provided with the unit), has a handle system and can be closed fully.

Store the inverter in a dry place where ambient temperatures are -25°C - +65°C / -13°F - 149°F.

# Chapter 2: Installing the Power Optimizers

## Safety

The following notes and warnings apply when installing the SolarEdge power optimizers. Some of the following may not be applicable to smart modules:

**WARNING!**

When modifying an existing installation, turn OFF the inverter ON/OFF switch and the AC circuit breaker on the main AC distribution panel.

**WARNING!**

Input and output connectors are not watertight until mated. Open connectors should be mated to each other or plugged with appropriate watertight caps.

**CAUTION!**

Power optimizers are IP65/NEMA4 rated. Choose a mounting location where optimizers will not be submerged in water.

**CAUTION!**

This unit must be operated according to the operating specifications provided with the unit.

**CAUTION!**

Cutting the power optimizer input or output cable connector is prohibited and will void the warranty.

**CAUTION!**

All PV modules must be connected to a power optimizer.

**CAUTION!**

If you intend to mount the optimizers directly to the module or module frame, first consult the module manufacturer for guidance regarding the mounting location and the impact, if any, on module warranty. Drilling holes in the module frame should be done according to the module manufacturer instructions.

**CAUTION!**

Installing a SolarEdge system without ensuring compatibility of the module connectors with the optimizer connectors may be unsafe and could cause functionality problems such as ground faults, resulting in inverter shut down. In order to ensure mechanical compatibility of the SolarEdge optimizers and the modules to which they are connected, use identical connectors from the same manufacturer and of the same type on both the power optimizers and on the modules.

**IMPORTANT SAFETY FEATURE**

Modules with SolarEdge power optimizers are safe. They carry only a low safety voltage before the inverter is turned ON. As long as the power optimizers are not connected to the inverter or the inverter is turned OFF, each power optimizer will output a safe voltage of 1V.

## Installation Guidelines

- Frame-mounted power optimizers are mounted directly on the module frame in rail-less racking systems. Mounting the power optimizers in advance saves installation time. For installation of frame-mounted power optimizers, refer to [http://www.solaredge.com/sites/default/files/installing\\_frame\\_mounted\\_power\\_optimizers.pdf](http://www.solaredge.com/sites/default/files/installing_frame_mounted_power_optimizers.pdf).



- The steps in this chapter refer to module add-on power optimizers. For smart modules, start from *Step 3: Connecting Power Optimizers in Strings* on page 13. Also refer to the documentation supplied with the smart modules.
- The power optimizer can be placed in any orientation.
- To allow for heat dissipation, maintain a 24.5 mm / 1" clearance distance between the power optimizer and other surfaces.
- If connecting more modules than optimizer inputs in parallel, use a branch cable (available from SolarEdge).
- Position the power optimizer close enough to its module so that their cables can be connected.
- Make sure to use optimizers that have the required output cable length. You cannot use extension cables between every two optimizers in a string; They may be used only to connect between rows/ arrays or between the string and the inverter.
- The minimum and maximum string length guidelines are stated in the power optimizer datasheets. Refer to the SolarEdge Site Designer for string length verification. The SolarEdge Site Designer is available on the SolarEdge website at <http://www.solaredge.com/products/installer-tools/site-designer#/>.
- Completely shaded modules may cause their power optimizers to temporarily shut down. This will not affect the performance of the other power optimizers in the string, as long as the minimum number of unshaded power optimizers connected in a string of modules is met. If under typical conditions fewer than the minimum optimizers are connected to unshaded modules, add more optimizers to the string.

#### NOTE



The images contained in the following sections are for illustrative purposes only and may vary depending on product models.

## Step 1: Mounting the Power Optimizers

For each of the power optimizers<sup>1</sup>:

1. Determine the power optimizer mounting location and use the power optimizer mounting brackets to attach the power optimizer to the support structure. For frame-mounted power optimizers follow the instructions supplied with the optimizers.
2. If required, mark the mounting hole locations and drill the hole.



#### CAUTION!

Do not drill through the power optimizer or through the mounting holes. The drilling vibrations can damage the power optimizer and will void the warranty.

3. Attach each power optimizer to the rack using the M6 (1/4") stainless steel bolts, nuts and washers. Apply torque of 9.5 N\*m / 7 lb\*ft.
4. Verify that each power optimizer is securely attached to the supporting structure or the module.



#### NOTE

Record power optimizer serial numbers and locations, as described in *Providing Installation Information* on page 30.

<sup>1</sup>Not applicable to smart modules.

## Step 2: Connecting a PV Module to a Power Optimizer



### NOTE

Images are for illustration purposes only. Refer to the label on the product to identify the plus and minus input and output connectors.

For each of the power optimizers<sup>1</sup>:

- Connect the Plus (+) output connector of the module to the Plus (+) input connector of the power optimizer.
- Connect the Minus (-) output connector of the module to the Minus (-) input connector of the power optimizer.

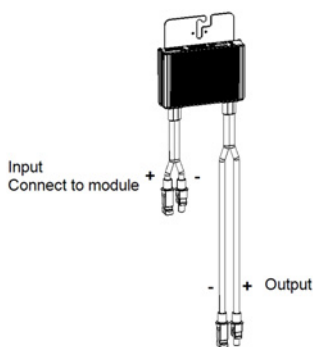

Figure 1: Power optimizer connectors

## Step 3: Connecting Power Optimizers in Strings

You can construct parallel strings of unequal length, that is, the number of power optimizers in each string does not have to be the same. The minimum and maximum string lengths are specified in the power optimizer datasheets. Refer to the SolarEdge Site Designer for string length verification.

### NOTE



- Use at least 11 AWG/ 4 mm<sup>2</sup> DC cables.
- The total cable length of the string (excluding power optimizers' cables) should not exceed:
  - For inverter models up to SE25K - 1000ft. /300m from DC+ to DC- of the inverter
  - For inverter models SE25K and larger - 2300ft. / 700m from DC+ to DC- of the inverter

1. Connect the Minus (-) output connector of the string's first power optimizer to the Plus (+) output connector of the string's second power optimizer.

2. Connect the rest of the power optimizers in the string in the same manner.

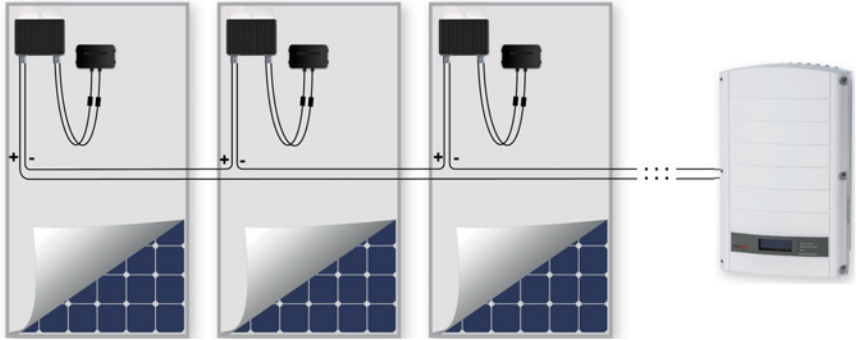

**Figure 2: Power optimizers connected in series**

3. If you intend to monitor the installation, using the SolarEdge monitoring platform, record the physical location of each power optimizer, as described in *Providing Installation Information* on page 30.



**WARNING!**

Input and output connectors are not watertight until mated. Open connectors should be mated to each other or plugged with appropriate watertight caps.

## Step 4: Verifying Proper Power Optimizer Connection

When a module is connected to a power optimizer, the power optimizer outputs a safe voltage of 1V. Therefore, the total string voltage should be equal to 1V times the number of power optimizers connected in series in the string. For example, if 10 power optimizers are connected in a string, then 10V should be produced.

Make sure the modules are exposed to sunlight during this process; otherwise, the power optimizers may not be powered. If you use a tracker, the power optimizer will turn ON only if the tracker is tracking the sun and the module provides at least 2W.

In SolarEdge systems, due to the introduction of power optimizers between the PV modules and the inverter, the short circuit current  $I_{SC}$  and the open circuit voltage  $V_{OC}$  hold different meanings from those in traditional systems.

For more information about the SolarEdge system's string voltage and current, refer to the  $V_{OC}$  and  $I_{SC}$  in *SolarEdge Systems Technical Note*, available on the SolarEdge website at: [http://www.solaredge.com/files/pdfs/isc\\_and\\_voc\\_in\\_solaredge\\_systems\\_technical\\_note.pdf](http://www.solaredge.com/files/pdfs/isc_and_voc_in_solaredge_systems_technical_note.pdf).



► **To verify proper power optimizers connection:**

Measure the voltage of each string individually before connecting it to the other strings or to the inverter. Verify correct polarity by measuring the string polarity with a voltmeter. Use a voltmeter with at least 0.1V measurement accuracy.

For troubleshooting power optimizer operation problems, refer to *Power Optimizer Troubleshooting* on page 58.

## Chapter 3: Installing the Inverter

Install the inverter either before or after the modules and power optimizers have been installed.



### CAUTION!

Do not rest the connectors at the bottom of the inverter on the ground, as it may damage them. To rest the inverter on the ground, lay it on its back, front or side.



### NOTE

- For single-phase 3-7.6kW inverters, use only copper conductors rated for a minimum of 75°C/167°F.
- For single phase 10-11.4kW inverters and for three-phase inverters, use only copper conductors rated for a minimum of 90°C/194°F.
- For three-phase inverters where opposite polarity DC conductors are routed in the same conduit, 1000V rated cables and components must be used.

## Inverter Package Contents

- One SolarEdge inverter
- One mounting bracket
- Two Allen screws for fastening the inverter to the mounting bracket
- Installation guide (with activation card and instructions)
- If a built in GSM/Wi-Fi modem is installed - RF antenna and mounting bracket
- AC ferrite bead kit

## Identifying the Inverter

Refer to the sticker on the inverter that specifies its **Serial Number** and its **Electrical Ratings**. Provide the serial number when contacting SolarEdge support. The serial number is also required when opening a new site in the SolarEdge monitoring platform.

In the following sections, unless otherwise indicated, instructions apply to both single-phase and three-phase inverters, though only one graphical example may be presented.

## Inverter Interfaces

The following figure shows the inverter connectors and components, located at the bottom of the inverter.

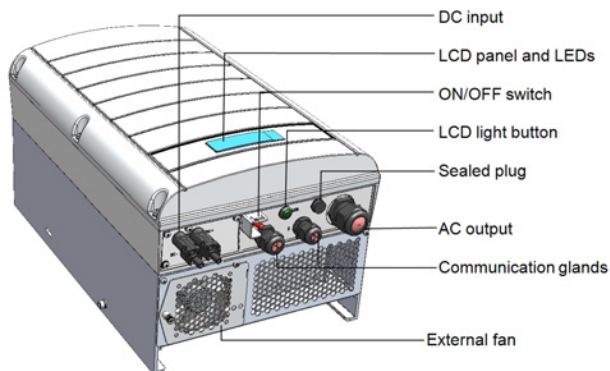

Figure 3: Inverter Interfaces



- **LCD panel:** displays inverter information and configuration parameters
- **LCD LEDs:** Three LEDs indicate the following inverter statuses:

Color	Description	Functionality
Green	Power production	<p><b>On</b> - The inverter is producing power.</p> <p><b>Blinking</b> - Standby mode. The inverter is in Standby mode until its working voltage is reached. The inverter then enters Production mode and produces power.</p> <p><b>Off</b> - The inverter is not producing power. This may be during Night mode, when the inverter ON/OFF switch is OFF or when an error occurs.</p>
Yellow	Module communication and inverter shutdown	<p><b>Blinking:</b></p> <ul style="list-style-type: none"> <li>◦ Monitoring information is being received from a power optimizer.</li> <li>◦ The inverter is being shut down.</li> </ul>
Red	Fault	<p><b>On</b> - There is an error. Refer to <i>Errors and Troubleshooting</i> on page 56 for more information.</p> <p><b>Blinking</b> - The inverter is being shut down.</p>

All LEDs turn on while the inverter is being configured.

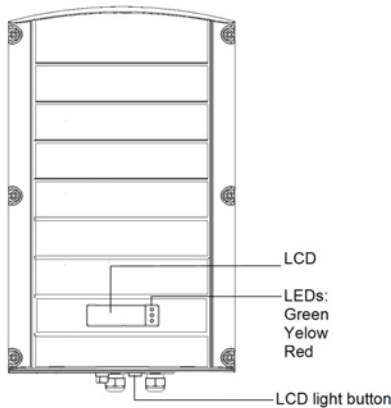

**Figure 4: Inverter front view**

- **AC output:** AC cable external gauge:
  - Single phase inverters: PG21 (9-16mm diameter)
  - Three phase inverters: M32 (15-21mm diameter)
- **DC inputs:** For connection of the PV installation
- **ON/OFF switch:** Turning this switch ON starts the operation of the power optimizers, enables power production and allows the inverter to begin exporting power to the utility grid. Turning it OFF reduces the power optimizer voltage to a low safety voltage and inhibits exportation of power. When this switch is OFF, the inverter control circuitry remains powered up.
- **LCD light button:** Pressing this button lights up the LCD for 30 seconds. In addition, you can press this button to view inverter status screens and access configuration menu options, as described *Configuring the Inverter Using the LCD Light Button* on page 34.
- **Two communication glands,** for connection of inverter communication options. Each gland has three openings. Refer to *Setting Up Communication* on page 47 for more information.

- **DC Safety Unit** (if applicable), including:
  - **ON/OFF switch:** connects and disconnects the DC power of the system
  - **AC output:** Cable gland for connection to the grid
  - **DC input:** Cable glands or MC4 connectors for connection of the PV installation
  - **Secondary grounding** (optional): Cable gland for grounding

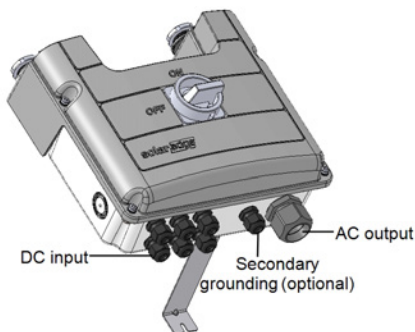

Figure 5: DC Safety Unit

## Mounting the Inverter

The inverter is typically mounted vertically, and the instructions in this section are applicable for vertical installation. Some SolarEdge three phase inverter models can be installed horizontally (above 10° tilt) as well as vertically, and at any tilt over 10° up to 90°. For information and instructions for horizontal mounting refer to [http://www.solaredge.com/sites/default/files/application\\_note\\_horizontal\\_mounting\\_of\\_three\\_phase\\_inverters.pdf](http://www.solaredge.com/sites/default/files/application_note_horizontal_mounting_of_three_phase_inverters.pdf).



The inverter is supplied with a mounting bracket.

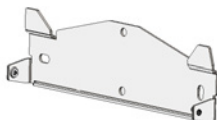

Figure 6: Mounting bracket



### NOTE

Make sure the mounting surface or structure can support the weight of the inverter and bracket, and make sure that it spans the width of the bracket.



### CAUTION!

**HEAVY OBJECT.** To avoid muscle strain or back injury, use proper lifting techniques, and if required - a lifting aid when removing or replacing.

1. Determine the inverter mounting location, on a wall, stud framing or pole, protected from direct solar irradiation. To allow proper heat dissipation, maintain the following minimum clearance areas between the inverter and other objects:

- If installing a single inverter:
  - At least 20 cm (8") to the top and bottom of the inverter; if installing an inverter with a DC Safety Unit, make sure to leave sufficient clearance for cable entry.
  - 10 cm (4") to the right and left of the inverter. For easy access to the fans (three phase inverters), you may leave larger clearance.
- If installing multiple inverters:
  - When installing inverters one above the other, leave at least 40 cm (16") between inverters. If installing an inverter with a DC Safety Unit, leave 20 cm (8") between the top of an inverter and the bottom of a DC Safety Unit).
  - When installing inverters side by side, follow these clearance specifications:

	Single Phase Inverters	Three Phase Inverters
Locations where the annual average high temperature <sup>1</sup> is below 25°C / 77°F	20 cm / 8" between inverters	20 cm / 8" between inverters
Locations where the annual average high temperature <sup>1</sup> is above 25°C / 77°F		40 cm / 16" between inverters

2. Position the mounting bracket against the wall/pole and mark the drilling hole locations (refer to *Mechanical Specifications* on page 59 for inverter and mounting bracket dimensions):
  - Ensure that the flat side of the bracket is at the bottom, as in *Figure 7*.
  - Use at least two bracket holes. Additional holes can be used to fix the bracket. Determine which and how many holes to use according to mounting surface type and material.
3. Drill the holes and mount the bracket. Verify that the bracket is firmly attached to the mounting surface.

**NOTE**



When mounting an inverter on an uneven surface, you may use spacers/ washers behind the top mounting hole of the bracket (see ). Depending on the angle, use the appropriate size and number of spacers so that the bracket is perpendicular to the ground. Recommended: a stainless steel 3/4" long screw, with a 1/4" socket button head , two jam nuts and three washers.

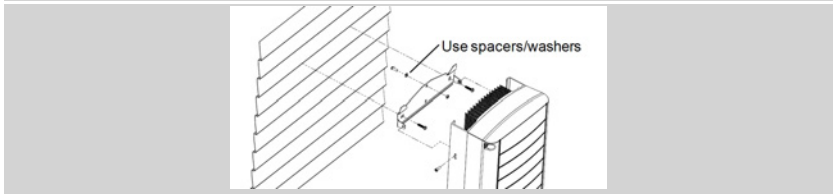

<sup>1</sup>Annual average high temperature – the average of the 12 monthly average highs, for example:

Average High Temperature												Years on Record: 20	
C	ANNUAL	JAN	FEB	MAR	APR	MAY	JUN	JUL	AUG	SEP	OCT	NOV	DEC
	21.5	11.8	12.6	15.4	21.5	25.3	27.6	29	29.4	28.2	24.7	18.8	14

Refer to <http://www.weatherbase.com/> to find the value in your location.

4. Hang the inverter on the bracket (see *Figure 7*): Lift the inverter from the sides, or hold it at the top and bottom of the inverter to lift the unit into place. Do not lift holding the DC Safety Unit as it may be damaged.
5. Align the two indentations in the inverter enclosure with the two triangular mounting tabs of the bracket, and lower the inverter until it rests on the bracket evenly.

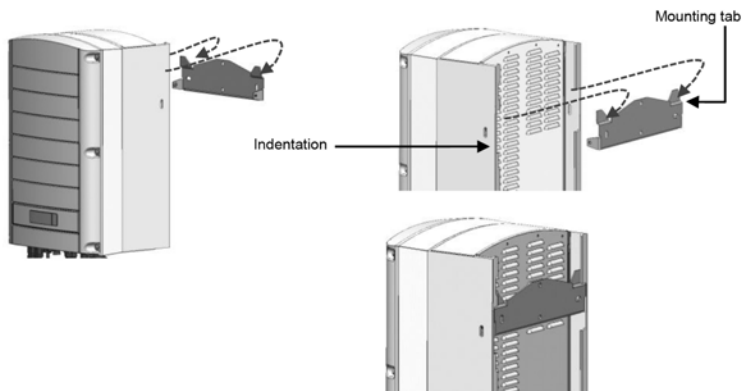

**Figure 7: Hanging the inverter on the bracket**

6. Optionally, secure the Safety Switch bracket to the wall:
7. For inverters with DC Safety Unit - secure the Safety Switch bracket to the wall:
  - Mark the location of the bracket screw for the Safety Switch StorEdge Connection Unit and drill the hole.
  - Fasten the bracket using a standard bolt.
  - Verify that the bracket is firmly attached to the mounting surface.

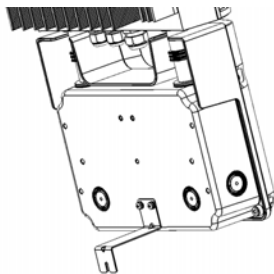

**Figure 8: Safety Switch bracket**

8. Insert the two supplied screws through the outer heat sink fin on both sides of the inverter and into the bracket. Tighten the screws with a torque of  $4.0 \text{ N}\cdot\text{m}$  /  $2.9 \text{ lb}\cdot\text{ft}$ .

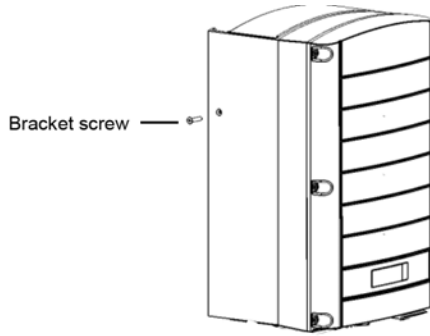

**Figure 9: Inserting the bracket screws**

## Chapter 4: Connecting the AC and the Strings to the Inverter

This chapter describes how to connect the inverter to the AC grid, and to the strings of modules with power optimizers.

If using an inverter with a DC Safety Unit, refer to the instructions in *Connecting the AC and DC Strings to the DC Safety Unit* on page 61.

Refer to the technical specifications provided with the inverter.

### Grid Connection Guidelines

#### NOTE

In most countries, SolarEdge three phase inverters require neutral connection at all times (only grids with neutral connection are supported)



In some countries, the SolarEdge three phase inverters can be connected to delta grids. Prior to system installation, refer to the Three Phase Inverters for Delta Grids application note and Supported Countries application note to confirm compatibility:

[http://www.solaredge.com/sites/default/files/se\\_inverters\\_supported\\_countries.pdf](http://www.solaredge.com/sites/default/files/se_inverters_supported_countries.pdf); installing without confirmation may void the inverter warranty.

- For installation on a delta grid without neutral, multiple single phase inverters can be used.
- For more wiring information refer to the *SolarEdge Recommended AC Wiring Application Note*, available on the SolarEdge website at <http://www.solaredge.com/files/pdfs/application-note-recommended-wiring.pdf>.



### Connecting the AC Grid to the Inverter

Use a three-wire cable for a single phase connection or a five-wire cable for three phase connection. The maximum wire size for the input terminal blocks is 16mm<sup>2</sup>.

1. Turn OFF the AC circuit breaker.
2. Open the inverter cover: Release the Allen screws and carefully move the cover horizontally before lowering it.



#### CAUTION!

When removing the cover, make sure not to damage internal components. SolarEdge will not be held responsible for any components damaged as a result of incautious cover removal.

3. Strip 58 mm / 2.32" of the external cable insulation and strip 8 mm / 0.32" of the internal wire insulation.

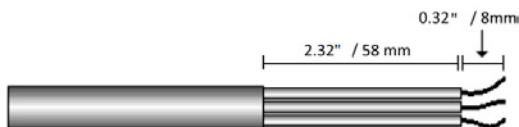

Figure 10: Insulation stripping – AC (3-wire cable)

4. Open the AC cable gland and insert the cable through the gland (see ).



#### WARNING!

Turn OFF the AC before connecting the AC terminals. If connecting equipment grounding wire, connect it before connecting the AC Line and Neutral wires.

5. For SE25K, SE27.6K, and SE33.3K three phase inverters, attach the supplied Ferrite bead to the AC wires:
  - a. Insert the AC wires through the supplied bead.
  - b. Connect the AC wires to the terminal blocks.
  - c. Tighten the wires to the bead using the supplied T-wrap.

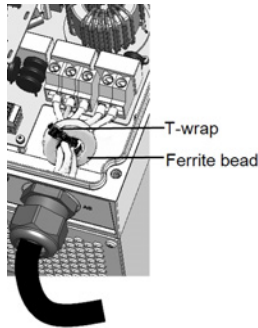

**Figure 11: Attaching a Ferrite bead in three phase inverters**

6. Depending on the inverter type (single phase or three phase), connect the AC, as follows. Connect the PE (grounding) wire first.

Single Phase Inverter	
Wire type	Connect to terminal
PE (grounding)	
Line	L
Neutral	N

**Figure 12: Single Phase Inverter AC Terminals**

Three Phase Inverter	
Wire type	Connect to terminal
Line 1	L1
Line 2	L2
Line 3	L3
PE (grounding)	
Neutral	N

**Figure 13: Three Phase Inverter AC Terminals**

**NOTE**

If power control is enabled, it is important to respect the order of grid lines connection to the inverter. A 120deg phase difference should be kept between L1 to L2 and between L2 to L3 (L1-L2-L3 and not, for example L1-L3-L2). If the grid lines are not in this order, an error is displayed on the LCD and the inverter will not produce power.



7. Connect the wires to the appropriate terminal block connectors in the inverter. Tighten the terminal block screws with a torque of 1.2-1.5 N\*m / 0.88-1.1 lb\*ft.
8. Check that the wires are fully inserted and cannot be pulled out easily.
9. Tighten the AC cable gland with a torque of 2.8-3.3 N\*m / 2.0-2.4 lb\*ft.
10. Verify that there are no unconnected wires to the inverter and that the unused terminal screws are tightened.

## Connecting the Strings to the Inverter

Connect the string to the DC input pairs. If required, connect additional strings in parallel using an external combiner box/branch cables before connecting to the inverter.

### NOTE



Functional electrical earthing of DC-side negative or positive poles is prohibited because the inverter has no transformer. Grounding (earth ground) of module frames and mounting equipment of the PV array modules is acceptable.

### NOTE



SolarEdge's fixed input voltage architecture enables the parallel strings to be of different lengths. Therefore, they do not need to have the same number of power optimizers, as long as the length of each string is within the permitted range.

Connect the DC connectors of each string to the DC+ and DC- connectors according to the labels on the inverter.

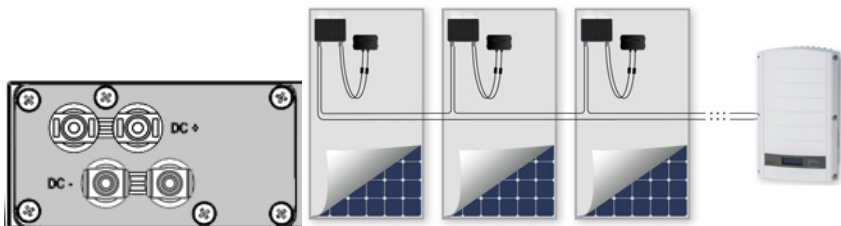

Figure 14: Inverter DC Connections

## Selecting a Residual Current Device (RCD)

### IMPORTANT SAFETY FEATURE



All SolarEdge inverters incorporate a certified internal Residual Current Device (RCD) in order to protect against possible electrocution and fire hazard in case of a malfunction in the PV array, cables or inverter. There are 2 trip thresholds for the RCD as required for certification (DIN VDE 0126-1-1). The default value for electrocution protection is 30 mA, and for slow rising current is 300 mA.

If an external RCD is required by local regulations, check which type of RCD is required for the relevant electric code. Install the residual-current device (RCD) in accordance with the applicable local standards and directives. SolarEdge recommends using a type-A RCD. The recommended RCD value is 100mA or 300mA unless a lower value is required by the specific local electric codes. For extended power three phase inverters (SE25K, SE27.6K and SE33.3K) an RCD value of 300mA should be used. When required by local regulations, the use of an RCD type B is permitted.

### NOTE



For multiple inverters, an RCD per inverter is required.



In installations where the local electric code requires an RCD with a lower leakage setting, the discharge current might result in nuisance tripping of the external RCD. The following steps are recommended to avoid nuisance tripping of the external RCD:

- Select the appropriate RCD for correct operation of the installation: An RCD with a rating of 30mA may actually trip at a leakage as low as 15mA (according to IEC 61008). High quality RCDs will typically trip at a value closer to their rating.
- Configure the trip voltage of the inverter' internal RCD to a lower value than the trip current of the external RCD. The internal RCD will trip if the current is higher than the allowed current, but because the internal inverter RCD automatically resets when the residual currents are low it saves the manual reset.

For detailed information, refer to the RCD Selection for SolarEdge Inverters Application Note, available on the SolarEdge website at

[http://www.solaredge.com/sites/default/files/application\\_note\\_ground\\_fault\\_rcd.pdf](http://www.solaredge.com/sites/default/files/application_note_ground_fault_rcd.pdf).



## **Demand Response Enabling Device (DRED)**

---

According to the AS/NZS 4777.2 standard, SolarEdge inverters set to any Australia or New Zealand country setting may require connecting an external Demand Response Enabling Device (DRED, provided by the utility) to the inverter power reduction interface (PRI).

For DRED connection and configuration, refer to <http://www.solaredge.com/sites/default/files/dred-connection-application-note.pdf>.



## Chapter 5: Commissioning the Installation

This chapter describes how to activate the system, pair the power optimizers to the inverter and verify the proper functioning of the system.

### Step 1: Activating the System

1. Verify that the inverter ON/OFF switch is OFF.
2. Move the DC Safety Unit (if applicable) to the OFF position.
3. Remove the inverter cover: Open the inverter cover's six Allen screws and carefully pull the cover horizontally before lowering it.



#### WARNING!

ELECTRICAL SHOCK HAZARD. Do not touch uninsulated wires when the inverter cover is removed.

4. Activate the inverter:
  - a. Verify that the card S/N matches the inverter S/N.
  - b. Insert the card into the "CARD" slot on the communication board.
  - c. Turn ON the AC switch of the main circuit board.
  - d. LCD shows: Running Script... → Done!

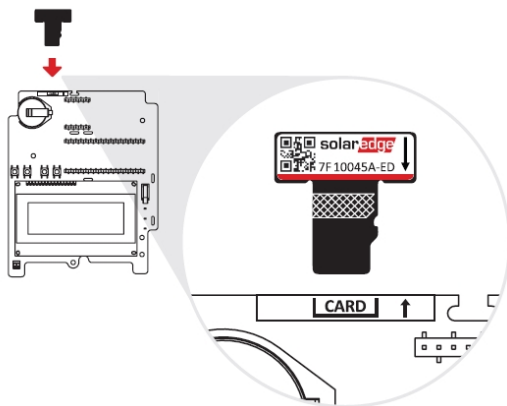

Figure 15: Activation card

If LCD shows: Failed:

- Turn AC OFF and ON (reset), and repeat the activation process.
- Use the activation code that appears on the certification inverter label to manually activate the inverter.
- If the problem persists, contact SolarEdge Support.



#### NOTE

You can use the activation code that appears on the certification inverter label to activate the inverter in case of a script error or a missing activation card.

5. Verify that the inverter is configured to the proper country: Press the LCD light button until reaching the ID status screen:

```

ID: ##### ##
DSP1/2: 1.0210 / 1.0034
CPU: 0003.19xx
Country: ESP

```

6. If required, perform the following additional steps before closing the inverter cover:
  - Country settings or inverter configuration using the internal LCD user buttons – refer to *Country and Grid* on page 36.
  - Communication options connection – refer to *Setting Up Communication* on page 47.
7. Close the inverter cover by tightening the screws with a torque of 9.0N\*m/ 6.6 lb\*ft. For proper sealing, first tighten the corner screws and then the two central screws. The following figure illustrates recommended order:

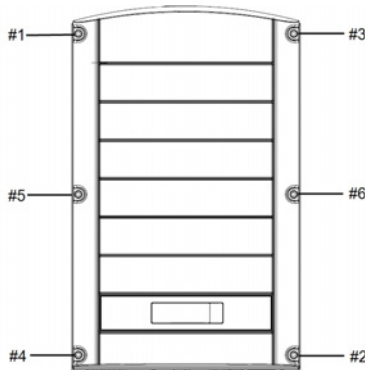

**Figure 16: Tightening order of the screws**

8. Turn ON the DC Safety Unit (if applicable). If an additional external DC switch is installed between the power optimizers and the inverter(s) then turn it ON.

A status screen similar to the following appears on the LCD panel:

```

Vac [ V ]   Vdc [ V ]   Pac [ w ]
240.7      14.1       0.0
P_OK: 000 / 000 < S_OK >
                OFF

```

9. Verify that the following information appears on the LCD panel:
  - **P\_OK**: Appears only upon pairing process completion and first telemetry reception from the power optimizers. Indicates connection to the power optimizers and that at least one power optimizer is sending monitoring data. If P\_OK does not appear, check the power optimizer, string and DC input connections.
  - **000/000**: Appears only upon first telemetry reception from the power optimizers. Indicates the number of power optimizers that have been paired to this inverter. At this stage, the number should be 000, since no power optimizers have been paired.
  - **S\_OK**: the connection to the SolarEdge monitoring platform is successful (should appear only if the inverter is connected to the server). If S\_OK is not displayed and the inverter is connected to the server, refer to *Errors and Troubleshooting* on page 56.
  - **Vac [V]**: the grid AC output voltage. Verify the correct value.

- **Vdc [V]:** The DC input voltage of the longest string connected to the inverter. There should be a safety voltage of 1V for each power optimizer in the string.

**NOTE**

A measurement error on the inverter LCD of  $\pm 3$  V is acceptable.

- **Pac [w]:** the AC output power (should be **0.0** since the inverter is OFF).
- **OFF:** the inverter ON/OFF switch is in the OFF position.

## Step 2: Pairing Power Optimizers to the Inverter

Once all connections are made, all the power optimizers must be logically paired to their inverter. The power optimizers do not start producing power until they are paired with an inverter. This step describes how to assign each inverter to the power optimizers from which it will produce power.

Perform this step when the modules are exposed to sunlight. If the string length is changed or a power optimizer is replaced, repeat the pairing process.

1. Perform pairing: Press and hold down the inverter LCD Light button for about **10 seconds**. The following message is displayed:

```
Keep holding button
for pairing, release
to enter menu...
Remaining:      3 sec
```

Keep holding for 5 seconds until the following is displayed:

```
Pairing
Turn Switch To On
```

2. Turn the inverter ON/OFF switch to ON within 5 seconds. If you wait longer than 5 seconds the inverter exits the pairing mode. The following message is displayed indicating that the inverter is performing the pairing:

```
Pairing
Remaining [sec]: 180
```

3. Wait for the completion of the pairing (remaining seconds is 0). If pairing fails, an error is displayed. In this case, repeat the pairing steps, and refer to *Power Optimizer Troubleshooting* on page 58. If the problem persists, contact SolarEdge Support. When pairing succeeds, the following message is displayed:

```
Pairing
Pairing Completed
```

The system startup process begins:

Since the inverter is ON, the power optimizers start producing power and the inverter starts converting AC.

**WARNING!**

When you turn ON the inverter ON/OFF switch, the DC cables carry a high voltage and the power optimizers no longer output a safe 1V output.

When the inverter starts converting power after the initial connection to the AC, the inverter enters Standby mode until its working voltage is reached. This mode is indicated by the flickering green inverter LED.

While the inverter is in Standby mode, it monitors the grid and verifies correct grid voltage and frequency. The following message is displayed:



```
Waking Up...
Remaining: 051 Sec
```

The countdown indicates the seconds remaining until entering the Production mode. This time is in accordance with local regulations and is typically between three to five minutes.

When countdown is complete, the inverter enters Production mode and produces power. The steadily lit green inverter LED indicates this mode.

## Step 3: Verifying Proper Activation

After the wake-up time is over, a status screen similar to the following appears on the inverter LCD panel:

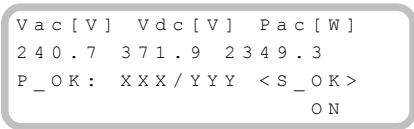

```
Vac [V]  Vdc [V]  Pac [W]
240.7   371.9   2349.3
P_OK:   XXX/YYY <S_OK>
                   ON
```

1. Verify the following:

- The green inverter LED is steadily lit.
- The ON/OFF indicator on the LCD panel reads **ON**.
- **P\_OK: XXX/YYY**: There is a connection to the power optimizers and at least one power optimizer is sending monitoring data. Optimizers send telemetries in a frequency of up to 10 minutes. Initially after pairing, both XXX and YYY values show 000 and the values increase as paired power optimizers are reported.



### NOTE

It may take up to 20 minutes for all power optimizers to transmit their telemetries and to be counted on the LCD screen.

- **S\_OK** appears, if the inverter is connected to the SolarEdge monitoring platform.
  - **Vac [V]** specifies the measured grid AC output voltage.
  - **Vdc [V]** : Specifies the DC input voltage, which should equal the sum of the output voltages of all modules (and should be within the operating range of the inverter).
  - **Pac [W]** specifies the AC output power produced.
2. Take note of the serial # on the inverter label using the detachable 2D barcode sticker on each device. This information is used in the SolarEdge monitoring platform to identify this inverter and is needed to open a new site in the monitoring platform.

Your SolarEdge power harvesting system is now operational.

## Step 4: Reporting and Monitoring Installation Data



### NOTE

This step requires connecting one of the communication options. Refer to *Setting Up Communication* on page 47.

### The SolarEdge Monitoring System

The SolarEdge cloud-based monitoring platform (monitoring platform) enables accessing SolarEdge site information, including up-to-date information viewed in a physical or logical view. The monitoring platform is described in detail in the *SolarEdge Monitoring Platform User Guide*, available on the SolarEdge website at

<http://www.solaredge.com/files/pdfs/solaredge-monitoring-platform-user-guide.pdf>.

The SolarEdge monitoring platform can display logical and physical layouts of the installed system, as follows:

- **Logical Layout:** Shows a schematic logical layout of the components in the system, such as: inverters, strings and modules, as well as their electrical connectivity. This view enables you to see which modules are connected in each string, which strings are connected to each inverter, and so on.
- **Physical Layout:** Shows a schematic physical layout of the components in the system, such as: inverters, strings and modules, as well as their electrical connectivity. This view enables a bird's eye view of the actual location of a system component.

Using the platform, you can:

- View the latest performance of specific components.
- Find under-performing components, such as modules, by comparing their performance to that of other components of the same type.
- Pinpoint the location of alerted components using the physical layout.
- See how components are connected to each other.
- Pair power optimizers remotely.

To display a logical layout, insert the inverter serial number in the new site created in the application. When the communication between the inverter and the monitoring server is established, the logical layout is displayed.

To display a physical layout, you need to map the locations of the installed power optimizers. To generate a physical mapping, use either the Site Mapper application or a mapping template, which should be filled out using the detachable stickers (see *Providing Installation Information*, below).

The logical and physical mapping can be used for debugging a problem using the SolarEdge monitoring platform.

If you do not report the physical and logical mapping of the installed power optimizers to SolarEdge, the SolarEdge monitoring platform will show the logical layout indicating which power optimizers are connected to which inverter, but will not show strings or the physical location of power optimizers.

The inverter may be connected to the SolarEdge monitoring platform via LAN or via an external modem connected to the inverter's RS232 connector. Alternatively, you can connect the inverter to another inverter that is already connected to the server, in a master-slave configuration. Refer to *Setting Up Communication* on page 47.



## Providing Installation Information

Use one of the following methods to connect your PV system to the SolarEdge cloud-based monitoring platform (monitoring platform).

### Site Mapper Application

#### Android

Use the SolarEdge Site Mapper smart-phone application to scan the power optimizer and inverter 2D bar-codes, and map the system physical layout in the SolarEdge monitoring platform. This application is integrated with the SolarEdge monitoring platform and enables:

- Simple on-site registration of new systems.
- Creating, editing and verifying system physical layout.
- Scanning and assigning the power optimizer serial number to the correct location in the system physical layout.

For detailed information, refer to the *SolarEdge Site Mapper* demo movies:

- [Creating new sites using the SolarEdge Site Mapper mobile application](#)
- [Mapping power optimizers using the SolarEdge Site Mapper mobile application](#)



#### iPhone

Use the SolarEdge Site Mapper smartphone application to scan the power optimizer and inverter 2D bar-codes. This application creates an XML file that can be uploaded to the SolarEdge monitoring platform during site registration. The SolarEdge Site Mapper can be downloaded from the application stores.

For detailed information, refer to the *SolarEdge Site Mapper Software Guide* or to the *Site Mapper* demo movie, available on the SolarEdge website at <http://www.solaredge.com/groups/installer-tools/site-mapper>.



### Creating a Site in the SolarEdge Monitoring Platform

Create the site in the monitoring platform using the registration form available at <https://monitoring.solaredge.com/solaredge-web/p/login>. Fill out all required information in the form, which includes information about your installation, as well as details about its logical and physical mapping.



### Paper Template

Fill out the Physical Layout Template (downloadable from the SolarEdge site) using the detachable 2D barcode stickers on each power optimizer. Once the form is completed, scan it and upload the scanned file to the SolarEdge monitoring platform during site registration. For an example paper template, refer to <http://www.solaredge.com/files/pdfs/physical-layout-template.pdf>.



## Chapter 6: User Interface

### LCD User Buttons

Four buttons are located inside the inverter above the LCD panel and are used for controlling the LCD menu, as shown below:

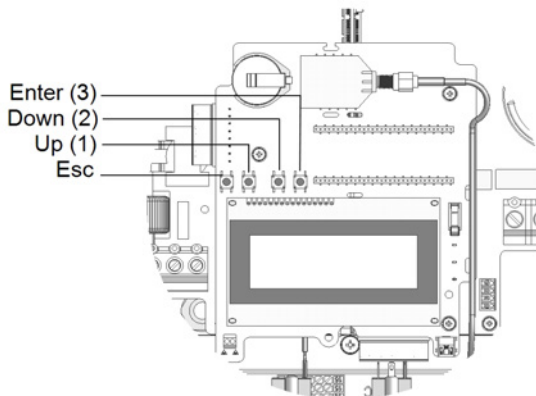

Figure 17: LCD Internal menu buttons

Use the four user buttons to control the LCD panel menus:

- **Esc:** Moves the cursor (>) to the beginning of the currently displayed parameter; goes to the previous menu, and cancels a value change with a long press (until **Aborted** is displayed).
- **Up (1) and Down (2):** Moves the cursor from one menu option to another, moves among the characters of a displayed parameter, and toggles between possible characters when setting a value.
- **Enter (3):** Selects a menu option and accepts a value change with a long press (until **Applied** is displayed).

Use the three rightmost buttons for entering **123** when entering the Setup mode password **12312312**.

The LCD screen displays status information of the system and various menus for configuration options. The LCD panel and buttons are used during the following processes:

- **Operational mode:** The LCD panel allows checking for proper system operation. Refer to *Status Screens - Operational Mode* on page 40 for a description of this option. Use the LCD light button to toggle through the informative displays.
- **Setup mode:** Upon installation, an installer may perform basic configuration, as described in *Inverter Configuration – Setup Mode* on page 31.
- **Error messages:** In the event of a problem, an error message may be displayed on the LCD panel. For more information, refer to <http://www.solaredge.com/sites/default/files/se-inverter-installation-guide-error-codes.pdf> and *Inverter Configuration – Setup Mode* on page 31.



## Inverter Configuration – Setup Mode

You can configure the inverter using one of the following:

- [The internal LCD user buttons.](#) When using this option, the inverter cover is removed.
- [The external LCD light button.](#) When using this option, removing the inverter cover is not required. This option of configuration includes a less detailed configuration menu.



## Configuring the Inverter Using the Internal LCD User Buttons

After inverter installation, an installer may perform basic system configuration. Configuration is done when the inverter is in Setup mode.

### ▶ To enter Setup mode:

1. Turn the inverter ON/OFF switch to OFF (AC remains ON).

#### WARNING!



If the inverter was operating properly (power was produced by the power optimizers), the following message is displayed.

```
DC VOLTAGE NOT SAFE
DO NOT DISCONNECT
VDC: 72.0
```

This message is displayed until the DC voltage is safe (50V). Do not open the cover until the voltage is safe or until at least five minutes have passed.

2. Press the Enter button for at least 5 seconds. The following message is displayed:

```
Please enter
Password
*****
```

3. Use the three rightmost internal LCD user buttons to type in the following password: **12312312**. The following menu is displayed:

```
Country <Italy>
Language <Eng>
Communication
Power Control
Display
Maintenance
Information
```

The inverter is now in Setup mode and all its LEDs are lit. The inverter automatically exits Setup mode if no buttons are pressed for more than 2 minutes.

The following shows a hierarchical tree of the menu options, which are described in *Configuration Menu Options* on page 36. Actual menus may vary from shown depending on the firmware version of the inverter and on the country.

Main menu:

```
Country <Italy>
Language <Eng>
Communication
Power Control
Display
Maintenance
Information
```

Country:

```
Germany+  
Spain  
France  
.  
.  
.
```

Language:

```
English  
German  
Spanish  
French  
Italian
```

Communication<sup>1</sup>

```
Server<LAN>  
LAN Conf  
RS485-1 Conf<S>  
RS485-2 Conf<S>  
ZigBee Conf<S>  
Wi-Fi Conf<N/A>  
Cellular Conf  
GPIO Conf <MTR>
```

Power Control<sup>2</sup>:

```
Grid Control <En>  
Energy Manager  
RRCR Conf.  
Reactive Pwr Conf.  
Active Pwr Conf.  
Phase Balance <Dis>  
Wakeup Conf.  
P(f)  
Advanced  
Load Defaults
```

Display:

```
Temperature <C>  
LCD On Time <30>  
TLM On Time <15>
```

<sup>1</sup>If ZigBee is connected, the Wi-Fi Conf menu is not displayed. If ZigBee is not connected, ZigBee Conf and Wi-Fi Conf are both displayed with <N/A>.

<sup>2</sup>Phase Balance is applicable to single phase inverters only.

## Maintenance:

```
Date and Time
Reset Counters
Factory Reset
FW Upgrade
Diagnostics
Grid Protection
Board Replacement
```

## Information:

```
Versions
Error Log
Warning log
Hardware IDs
```

## Configuring the Inverter Using the LCD Light Button

Use the LCD light button for communication setup and for displaying the Error log and Warning Log without having to open the Inverter cover. There are fewer menus available when using this configuration option; however, the functionality of these menus is the same as when using the internal LCD user buttons.

1. Turn the inverter ON/OFF switch to OFF.
2. Press and hold down the LCD light button until the following message is displayed:

```
Keep holding button
for pairing, release
to enter menu...
Remaining:      3 sec
```

Releasing the button displays the following menu:

```
Optimizer pairing
Language <eng>
Communication
Maintenance
Information
Exit
```

3. Short-press (one second) to scroll down to the next menu option, and long-press (three seconds) to select the item. You can use the **Exit** option in these menus to move up one menu level or to exit the Setup mode from the main menu.

The following shows a hierarchical tree of the menu options that appear when using the LCD light button:

Main menu:

```
Optimizer pairing
Language <eng>
Communication
Maintenance
Information
Exit
```

Language:

```
English
German
Spanish
French
Italian
Exit
```

Communication1:

```
Server<LAN>
LAN Conf
RS485-1 Conf<S>
ZigBee Conf<S>
Wi-Fi Conf<N/A>
GPIO Conf <MTR>
RS232 Conf
Cellular Conf
Exit
```

Information:

```
Versions
Error Log
Warning log
Hardware IDs
Exit
```

Maintenance:

```
Date and Time
Reset Counters
Factory Reset
SW Upgrade-SD Card
Diagnostics
Grid Protection
Board Replacement
Exit
```

The options presented in these menus are described in the next section.

---

<sup>1</sup>If Wi-Fi is connected, the ZigBee Conf menu is not displayed, and vice versa.

## Configuration Menu Options

This section describes how to use the LCD menus for configuring the inverter. Configuration is only available when the inverter ON/OFF switch is OFF. Use either the internal LCD user buttons or the external LCD light button to move between and select menu options.

### Country and Grid

Configuring the country and grid is available using the internal user buttons only.

1. Select the **Country** option to specify the country in which the inverter is installed and the grid to which it is connected. This parameter may arrive pre-configured. If so, verify that it is set to the proper country.



#### WARNING!

The inverter must be configured to the proper country in order to ensure that it complies with the country grid code and functions properly with that country grids.

A list of countries is displayed. If no country is configured, the value is <NONE>.



#### NOTE

If an inverter is not configured to any country, it will not produce energy, and the following message will be displayed on the LCD:

No Country Selected

A plus sign (+) near the country indicates that another menu will be displayed after selection.

2. Confirm your country selection in the confirmation screen: Toggle to **YES** and press **Enter**.

### Language

1. Select the **Language** option to set the language in which the LCD should display.
2. Confirm your language selection in the confirmation screen: Toggle to **YES** and press **Enter**.

### Communication

1. Select the **Communication** option to define and configure:
  - The communication option used by the inverter to communicate with the SolarEdge monitoring platform
  - The communication option used to communicate between multiple SolarEdge devices or other external non-SolarEdge devices, such as electricity meters or loggers.
2. Select **Server** to set which communication method is used to communicate between devices and the SolarEdge monitoring platform. Refer to *Setting Up Communication* on page 47 for a full description of these communication options.



#### NOTE

The Server menu shows only the communication options installed in the inverter.

The following shows a hierarchical tree of the menu options in the **Communication** menu.

For detailed information about all the configuration options, refer to the *Communication Options Application Note*, available on the SolarEdge website at [http://www.solaredge.com/files/pdfs/solaredge-communication\\_options\\_application\\_note\\_v2\\_250\\_and\\_above.pdf](http://www.solaredge.com/files/pdfs/solaredge-communication_options_application_note_v2_250_and_above.pdf).



## Communication1:

```
Server<LAN>
LAN Conf
RS485-1 Conf<S>
RS485-2 Conf<S>
ZigBee Conf<S>
Wi-Fi Conf<N/A>
Cellular Conf
GPIO Conf <MTR>
```

## Server:

```
LAN
RS485
Zigbee
Wi-Fi
Cellular
None
```

## LAN Conf:

```
IP Config
Set DHCP <en>
Set IP
Set Mask
Set Gateway
Set DNS
Set Server Addr
Set Server Port
Modbus TCP<Dis>
```

## RS485-1 Conf:

```
Device Type <SE>
Protocol <M>
Device ID <1>
Slave Detect <#>
Slave List <#>
```

## ZigBee Conf. (enabled only if the ZigBee internal card is connected):

```
Device Type<SE>
Protocol<MPS>
Device ID<1>
PAN ID
Scan Channel
Load ZB Defaults
```

<sup>1</sup>If ZigBee is connected, the Wi-Fi Conf menu is not displayed. If ZigBee is not connected, ZigBee Conf and Wi-Fi Conf are both displayed with <N/A> and their menus are not accessible.

Wi-Fi Conf (enabled only if the internal card is connected):

```
Scan Networks
Set key
Load Defaults
```

GSM Conf:

```
Device Type<SE>
Protocol<GSM>
Set APN
Set Modem Type
Set User Name
Set Password
```

GPIO Conf:

```
Device Type <RRCR>
```

## Power Control

For detailed information about active and reactive power control options refer to the *Power Control Application Note*, available on the SolarEdge website at [http://www.solaredge.com/files/pdfs/application\\_note\\_power\\_control\\_configuration.pdf](http://www.solaredge.com/files/pdfs/application_note_power_control_configuration.pdf).



```
Grid Control <En>
Energy Manager
RRCR Conf.
Reactive Pwr Conf.
Active Pwr Conf.
Phase Balance <Dis>
Wakeup Conf.
P (f)
Advanced
Load Defaults
```

The Grid Control option is disabled by default. Enabling it opens additional options in the menu.

For P(Q) diagram refer to [https://www.solaredge.com/sites/default/files/application\\_note\\_p\\_q\\_diagram\\_of\\_se\\_inverters\\_en\\_and\\_na.pdf](https://www.solaredge.com/sites/default/files/application_note_p_q_diagram_of_se_inverters_en_and_na.pdf)



### NOTE



SolarEdge inverters with "Grid Support" functionality (as marked on the inverter certification label), are compliant with Subject 1741 Addition of a Supplement for Grid Support Utility Interactive Inverters from May 2nd, 2016. The functionality is built into the inverter and no additional external device is required.

## Display

Select **Display** to set the following:

```
Temperature <C>
LCD On Time <30>
TLM On Time <15>
```

- **Temperature:** Select Celsius or Fahrenheit units.
- **LCD On Time <30>:** The number of seconds that the LCD backlight is ON after pressing the LCD light button. Set a value within the range of 10-120 seconds.
- **TLM On Time <15>:** The number of minutes that the LCD backlight is ON while viewing the Telemetry window. Set a value within the range of 1-120 minutes.

## Maintenance

Select **Maintenance** to set the following options:

```
Date and Time
Reset Counters
Factory Reset
FW Upgrade
Diagnostics
Grid Protection
Board Replacement
```

- **Date and Time:** Set the internal real-time clock. If connected to the SolarEdge monitoring platform, the date and time are set automatically and only time zone should be set.
- **Reset Counters:** Resets the accumulated energy counters that are sent to the SolarEdge monitoring platform
- **Factory Reset:** Performs a general reset to the default device settings.
- **FW Upgrade:** Perform a software upgrade by using an SD card. Refer to [upgrading an inverter using micro sd card.pdf](#).
- **Diagnostics:** Displays the Isolation Status and optimizers status screens. Refer to [www.solaredge.com/files/pdfs/application\\_note\\_isolation\\_fault\\_troubleshooting.pdf](http://www.solaredge.com/files/pdfs/application_note_isolation_fault_troubleshooting.pdf).
- **Standby Mode:** Enables/disables Standby Mode - for remote commissioning.
- **Grid Protection:** Available in specific countries. Enables viewing and setting grid protection values.
- **Board Replacement:** Backs up the system parameters; Used during board replacement according to the instructions supplied with replacement kits.



## Information

Select **Information** to display the following options:

```
Versions
Error Log
Warning log
Hardware IDs
```



- **Versions:** Displays inverter firmware versions:
  - **ID:** The inverter ID.
  - **DSP 1/2:** The DSP digital control board firmware version
  - **CPU:** The communication board firmware version



#### NOTE

Please have these numbers ready when you contact SolarEdge Support.

- **Error Log:** Displays the last five errors.
- **Warning Log:** Displays the last five warnings.
- **Hardware IDs:** Displays the following HW serial numbers (if exist, and connected to the inverter):
  - **ID:** the inverter's ID
  - **RGM1** (Revenue Grade Meter): Modbus meter (with lower Modbus ID)
  - **RGM2:** A second external Modbus meter (with the higher Modbus ID)
  - **ZB:** Zigbee MAC address
  - **Cell:** MEID (CDMA) or IMEI (GSM)
  - **WiFi:** Wi-Fi MAC address

## Status Screens - Operational Mode

During normal operation pressing the external LCD light button turns on the LCD backlight. Additional presses display the following screens one after the other.

### Initial Status

```
Vac [ V ]   Vdc [ V ]   Pac [ W ]
240 . 7     371 . 9     2349 . 3
P _ O K :   X X X / Y Y Y < S _ O K >
                                O N
```

- **Vac [V]:** The AC output voltage
- **Vdc [V]:** The DC input voltage
- **Pac [W]:** The AC output power
- **P\_OK: XXX/YYY:** There is a connection to the power optimizers and at least one power optimizer is sending monitoring data. XXX is the number of power optimizers for which telemetries have been received in the last two hours. YYY is the number of paired power optimizers identified during the most recent pairing process. If XXX and YYY are not equal, there may be a problem in one or more power optimizers.
- **S\_OK:** The connection to the SolarEdge monitoring platform is successful (appears only if the inverter is connected to the server).
- **ON/OFF:** Indicates the position of the inverter ON/OFF switch.

### Main Inverter Status

```
Vac [ V ]   Vdc [ V ]   Pac [ W ]
240 . 7     371 . 9     3210 . 0
Fac [ Hz ]   O P s _ O k   Temp
50 . 0       11           28 . 2
```

- **Vac [V]:** The AC output voltage.
- **Vdc [V]:** The DC input voltage.
- **Pac [W]:** The AC output power.
- **Fac [Hz]:** The AC output frequency.
- **OPs\_Ok:** Number of optimizers sending telemetries (indicating that they are paired)
- **Temp [C or F]:** The inverter heat sink temperature

## Energy Meter Status

Displays the total energy produced during the last day, month, year and since inverter installation.

```
Day [ Wh ] :      0 . 0
Month [ kWh ] :   0 . 0
Year [ kWh ] :    0 . 0
Total [ kWh ] :   0 . 0
```

If a meter is connected to the inverter, the following status screen, showing the power and energy readings, is displayed instead of the above screen.

If the meter is set to Export +Import, there are two status screens, with the first line displaying: "Export Meter" or "Import Meter". The following is an example of an export meter status:

```
Export Meter
Status :      <OK / Error# >
Power [ W ] :      x x x x x . x
Energy [ Wh ] :    X X X X X . X
```

- **Status:** Displays OK if the meter is communicating with the communication board.
- **<Error message>:** If there is a meter error, it is displayed in this line.
- **Power (W):** Depending on the meter type connected to the inverter, this line displays the exported or imported power in Watts.
- **Energy (Wh):** The total energy read by the meter, in Watt/hour. The value displayed in this line depends on the meter type connected to the inverter and its location:
  - If a bidirectional meter is connected at the consumption point, this value is the consumed energy.
  - If the meter is installed at the production connection point, this value is the energy produced by the site.
  - If the meter is installed at the grid connection point, this value is the energy exported to the grid.

If the inverter is connected to the SolarEdge server, this value will also be displayed in the monitoring platform.



### NOTE

This data is accumulated according to an internal real-time clock.

## Telemetry Status

This screen displays the last power optimizer telemetry received. The display changes as each power optimizer sends its telemetry.

In order to verify proper installation, the installer may view the Telemetry window for some time in order to observe the power optimizers' report process.

```

Module : 10288063 1B
Energy [Wh] : 56.7
Vdc_O [V] : 40.0
Vdc_I [V] : 38.3
I_in [A] : 7.8
Temp [C] : 28.0

```

- **Module:** Power optimizer serial number
- **Energy:** power optimizer energy
- **Vdc\_O:** Power optimizer output voltage
- **Vdc\_I:** Power optimizer input voltage (module voltage)
- **I\_in:** Power optimizer input current
- **Temp:** Power optimizer temperature

## ID Status

This screen displays the inverter software version and the country to which the inverter is configured.

```

ID : ##### ##
DSP1/2 : 1.0210 / 1.0034
CPU : 0003.19xx
Country : ESP

```

- **ID:** The inverter ID.
- **DSP 1/2:** The DSP digital control board firmware version
- **CPU:** The communication board firmware version
- **Country:** the current country setting

## Server Communication Status

```

Server : LAN <S_OK>
Status : <OK>
xxxxxxx
<ERROR MESSAGE>

```

### NOTE



If the connection method is CDMA (Cellular) or GSM, the server screen is replaced with the Cellular or GSM status screens (see *Status Screens - Operational Mode* on page 40 and *GSM Status* on page 43).

- **Server:** The method of connection to the SolarEdge monitoring platform.
- **S\_OK:** The connection to the SolarEdge monitoring platform is successful (should appear only if the inverter is connected to the server).
- **Status:** Displays OK if the inverter established successful connection and communication with the specified server port/device (LAN, RS485, Wi-Fi or ZigBee card).
- **xxxxxxx:** Eight-bit Ethernet communication connection status: A string of 1s and 0s is displayed. 1 indicates OK, 0 indicates an error. For a list of the possible errors and how to troubleshoot them, refer to *Troubleshooting Communication* on page 56

- **Error message**, according to failure. Refer to <http://www.solaredge.com/sites/default/files/se-inverter-installation-guide-error-codes.pdf>.



## IP Status

This screen describes the Ethernet configuration: IP, Mask, Gateway and MAC address (Media Access Control) of the Inverter.

```
IP 192.168.2.119
MSK 255.255.255.0
GW 192.168.2.1
MAC 0-27-02-00-39-36
```

## ZigBee Status

This screen describes the ZigBee configuration:

```
PAN : XXXXX
CH : XX / XXXX RSSI : <L>
MID : XXXX XX
```

- **RSSI**: The receive signal strength indication of the closest ZigBee in the system. L = low, M = medium, H = high and (-) = no signal.
- **PAN ID**: The ZigBee transceiver PAN ID
- **Ch.**: The ZigBee transceiver channel
- **ID**: The ZigBee transceiver ID
- **MID**: The Master ID of the coordinator (master) ZigBee card. This field is shown only in devices with router (slave) ZigBee cards, and after a successful ZigBee association. If a ZigBee card is not connected, a **No ZigBee** message is displayed instead of the **MID** field.

## Wi-Fi Status

This screen describes the Wi-Fi configuration:

```
IP : 192.168.2.119
GW : 192.168.2.1
SSID : xxxxxxxx
RSSI : <L/M/H/->
```

- **IP**: The DHCP provided address
- **GW**: The gateway IP address
- **SSID**: Service Set Identifier - the name of a wireless local area network (WLAN). All wireless devices on a WLAN must employ the same SSID in order to communicate with each other.
- **RSSI**: The receive signal strength indication of the closest Wi-Fi in the SolarEdge system. L = low, M = medium, H = high and - = no signal.

## GSM Status

If a GSM modem is connected, this screen replaces the Server status screen:

```
Server: Cell <S_OK>
Status: <OK>
MNO: <xxxxxxx> Sig: 5
<Error message>
```

- **Server:** The method of communication to the SolarEdge monitoring platform. Should display **Cell**.
- **Status:** Displays OK if the inverter established a successful physical connection to the modem.
- **S\_OK:** The last communication to the SolarEdge monitoring platform was successful (appears if the inverter is connected to the platform). If S\_OK is not displayed, refer to *Status Screens - Operational Mode* on page 40.
- **MNO:** The mobile network operator name
- **Sig:** The signal strength, received from the modem. A value between 0-5, (0 = no signal; 5=excellent signal).
- **Error message:** per communication connection status failure

## Communication Ports Status

```

      Dev  Prot  ##
RS485-1 <SE><S  > <-->
ZigBee  <SE><MPS><-->
    
```

- **##:** The total number of slaves detected on the specific port
- **Dev:** The type of device that was configured to a specific port (based on the port’s functionality), as follows:
  - **SE:** SolarEdge device (default)
  - **LGR:** Non-SolarEdge logger
  - **MLT:** Multiple devices, such as meters and batteries
  - **HA:** Home automation devices (for load management)
- **PROT:** The protocol type to which the port is set:
  - For a SolarEdge device:

RS485 protocol	ZigBee protocol
<b>S:</b> SolarEdge slave	
<b>M:</b> SolarEdge master	
	<b>P2P:</b> ZigBee point-to-point
	<b>MPM:</b> ZigBee multipoint master (for the SolarEdge ZigBee home gateway or for load management by the inverter)
	<b>MPS:</b> ZigBee multipoint slave (for a ZigBee router card)

- For electricity meters, refer to the *application note - Connecting an Electricity Meter to SolarEdge Devices* at <http://www.solaredge.com/files/pdfs/solaredge-meter-installation-guide.pdf>.
- **SS:** SunSpec - for a non-SolarEdge logger (monitoring and control)



## Smart Energy Management Status

This screen is displayed only when Smart Energy Management is enabled. The screen shows energy details of the site:

```

Site Limit:      7.0 kW
Site Prod:       10.0 kW
Site Export:     4.0 kW
Self-consume:   6.0 kW
    
```

- **Site Limit:** The limit that was defined for the site
- **Site Prod:** The power produced by the site
- **Site Export:** The power that is fed into the grid
- **Self-consume:** The PV power consumed by the site

For more information, refer to the *Export Limitation Application Note*, available on the SolarEdge website at [http://www.solaredge.com/files/pdfs/products/feed-in\\_limitation\\_application\\_note.pdf](http://www.solaredge.com/files/pdfs/products/feed-in_limitation_application_note.pdf).



## Fan Status

This screen is applicable to inverters equipped with external or internal fans, and provides information about the fan status:

```
Fan Status :
Fan1 : Not Working
Fan2 : Operating
```

or

```
Fan Status :
Int : Not Working
Ext : Operating
```

Each fan can have one of the following statuses:

- **Operating:** Fan OK
- **Not Working:** This status may indicate a system error and not necessarily a faulty fan. Turning AC OFF and ON again may clear this status. If the status does not change, replace the fan.

For more information, refer to *External Fan Maintenance and Replacement* on page 66.

## Power Control Status

This screen is displayed only when Power Control is enabled (available from communication board (CPU) firmware version 2.7xx/3.7xx and later).

```
PWR CTRL : REMOTE
PWR Limit : 10.04 kW
CosPhi : 0.9
Power Prod : 7000W
```

- **PWR CTRL:** The power control status:
  - **REMOTE** - Communication with the RRCR or smart energy manager is confirmed/validated.
  - **LOCAL** - The power is controlled locally (e.g. by a fixed limit), or this inverter limits the PV power production to its relative portion of the feed-in power limit, as a result of disconnected communication with the smart energy manager. If this status appears, check the communication to the smart energy manager or the communication to the meter.

- **PWR Limit:** The inverter maximum output power set by one of the power limiting options:
  - RRCR
  - Smart energy manager (Feed-in limitation)
  - P(f)
  - P(U)
  - Q(U)
- **Cos Phi:** The ratio between active to reactive power
- **Power Prod:** The power produced by the inverter

For more information, refer to the *Power Control Application Note*, available on the SolarEdge website at [http://www.solaredge.com/files/pdfs/application\\_note\\_power\\_control\\_configuration.pdf](http://www.solaredge.com/files/pdfs/application_note_power_control_configuration.pdf).



## Chapter 7: Setting Up Communication

Power optimizers send information to the inverter via the DC power lines (the PV output circuit). The information is sent from the inverter to the SolarEdge monitoring platform through the Internet. In order to send the data from the inverter, a communication connection must be set up, as described in this chapter.



### CAUTION!

When connecting the communication cables, make sure that the ON/OFF switch at the bottom of the inverter is turned OFF, and the AC is turned OFF.

When configuring the communication parameters, make sure that the ON/OFF switch is OFF, and the AC is turned ON.

## Communication Options

### Ethernet

Ethernet is used for a LAN connection. For connection instructions refer to *Creating an Ethernet (LAN) Connection* on page 49.

### RS485

RS485 is used for the connection of multiple SolarEdge devices on the same bus in a master-slave configuration. RS485 can also be used as an interface to external devices, such as meters and third party data loggers.

For connection instructions refer to *Creating an RS485 Bus Connection* on page 51.

### ZigBee

There are two types of ZigBee products.

- Wireless Communication ZigBee Kit - this option enables wireless connection of one or several devices to a ZigBee gateway, for wireless communication to the SolarEdge monitoring server.

This kit is provided with an installation guide, which should be reviewed prior to connection see <https://www.solaredge.com/sites/default/files/se-zigbee-home-gateway-installation-guide.pdf>.



- Device Control ZigBee card - this option enables wireless connection of one or several devices to Device Control product, which automatically divert PV energy to home appliances (home automation).

This option is provided with an installation guide, which should be reviewed prior to connection see <https://www.solaredge.com/sites/default/files/se-device-control-zigbee-module-installation-guide.pdf>



### Wi-Fi

This communication option enables using a Wi-Fi connection for connecting to the SolarEdge monitoring platform.

The Wi-Fi kit can be purchased separately and assembled during system installation. The Wi-Fi kit is provided with a user manual, which should be reviewed prior to connection. It is available on the SolarEdge website at [http://www.solaredge.com/sites/default/files/se\\_wifi\\_communication\\_solution\\_installation\\_guide.pdf](http://www.solaredge.com/sites/default/files/se_wifi_communication_solution_installation_guide.pdf)





## GSM

This wireless communication option (purchased separately) enables using a GSM connection to connect one or several devices to the SolarEdge monitoring platform.

The GSM cellular modem is provided with a user manual, which should be reviewed prior to connection. More information is available on the SolarEdge website at refer to the supplied manual, also available at [http://www.solaredge.com/sites/default/files/cellular\\_gsm\\_installation\\_guide.pdf](http://www.solaredge.com/sites/default/files/cellular_gsm_installation_guide.pdf)



Only communication products offered by SolarEdge are supported.  
Always connect the communication options when the inverter is OFF.

## Communication Connectors

Two communication glands are used for connection of the various communication options. Each gland has three openings. The table below describes the functionality of each opening. Unused openings should remain sealed.

Gland#	Opening	Functionality	Cable Size (diameter)
1 (PG16)	One small	External antenna cable	2-4 mm
	Two large	Ethernet connection (CAT5/6), ZigBee, or Wi-Fi	4.5-7 mm
2 (PG13.5)	All three	RS485, power reduction	2.5-5 mm

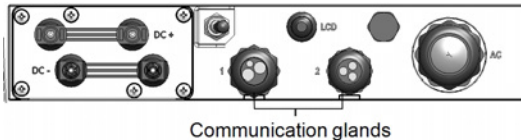

**Figure 18: Communication Glands**

The communication board has a standard RJ45 terminal block for Ethernet connection, and a 9-pin terminal block for RS485 connection, as shown below:

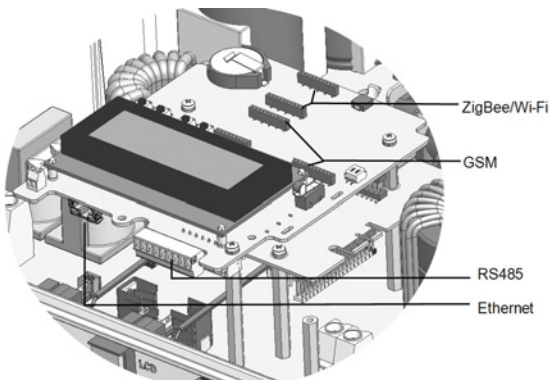

**Figure 19: Internal connectors**

## Removing the Inverter Cover

If the inverter cover is not already removed, use the following procedure for cover removal for communication connection or maintenance purposes.

1. Turn the inverter ON/OFF switch to OFF.
2. Disconnect the AC to the inverter by turning OFF the circuit breakers on the distribution panel. Wait 5 minutes for the capacitors to discharge.
3. Open the inverter cover's six Allen screws and carefully pull the cover horizontally before lowering it.



**CAUTION!**

When removing the cover, make sure not to damage internal components. SolarEdge will not be held responsible for any components damaged as a result of incautious cover removal.

## Creating an Ethernet (LAN) Connection

This communication option enables using an Ethernet connection to connect the inverter to the monitoring platform through a LAN.

Ethernet cable specifications:

- Cable type – a shielded Ethernet cable (Cat5/5E STP) may be used
- Maximum distance between the inverter and the router – 100 m/ 330 ft.

**NOTE**

If using a cable longer than 10 m / 33 ft in areas where there is a risk of induced voltage surges by lightning, it is recommend to use external surge protection devices. For details refer to:

[http://www.solaredge.com/files/pdfs/lightning\\_surge\\_protection.pdf](http://www.solaredge.com/files/pdfs/lightning_surge_protection.pdf).

If not using surge protection, connect the grounding wire to the first inverter in the RS485 chain; make sure the grounding wire is not in contact with other wires. For inverters with a DC Safety Switch, connect the grounding wire to the grounding bus-bar in the DC Safety Switch.

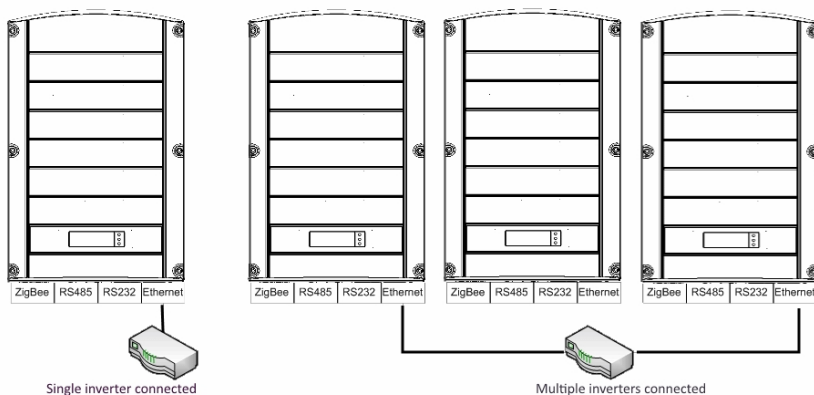

Figure 20: Example of Ethernet connection

**To connect the Ethernet cable:**

1. Remove the inverter cover .
2. Open the communication gland #1.



**CAUTION!**  
The gland includes a rubber waterproof fitting, which should be used to ensure proper sealing.

3. Remove the plastic seal from the large opening that has a cut in the rubber fitting .
4. Remove the rubber fitting from the gland and insert the CAT5/6 cable through the gland and through the gland opening in the inverter .
5. Push the cable into the cut opening of the rubber fitting.

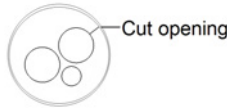

**Figure 21: Rubber fitting**

CAT5/6 standard cables have eight wires (four twisted pairs), as shown in the diagram below. Wire colors may differ from one cable to another. You can use either wiring standard, as long as both sides of the cable have the same pin-out and color-coding.

RJ45 Pin #	Wire Color <sup>1</sup>		10Base-T Signal 100Base-TX Signal
	T568B	T568A	
1	White/Orange	White/Green	Transmit+
2	Orange	Green	Transmit-
3	White/Green	White/Orange	Receive+
4	Blue	Blue	Reserved
5	White/Blue	White/Blue	Reserved
6	Green	Orange	Received-
7	White/Brown	White/Brown	Reserved
8	Brown	Brown	Reserved

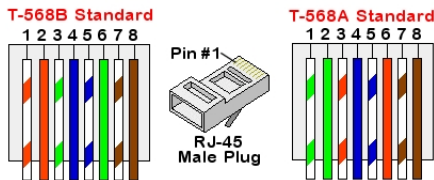

**Figure 22: Standard cable wiring**

<sup>1</sup>The inverter connection does not support RX/TX polarity change. Supporting crossover Ethernet cables depends on the switch capabilities.

6. Use a pre-terminated cable to connect via gland #1 to the RJ45 plug on the inverter's communication board or, if using a spool of cable, connect as follows:
  - a. Insert the cable through gland #1.
  - b. Remove the cable's external insulation using a crimping tool or cable cutter and expose eight wires.
  - c. Insert the eight wires into an RJ45 connector, as described in *Figure 22*
  - d. Use a crimping tool to crimp the connector.
  - e. Connect the Ethernet connector to the RJ45 port on the communication board.

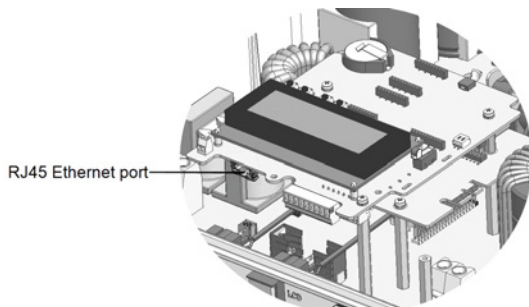

**Figure 23: The RJ45 Ethernet connection**

7. For the switch/router side, use a pre-terminated cable or use a crimper to prepare an RJ45 communication connector: Insert the eight wires into the RJ45 connector in the same order as above (*Figure 22*).
8. Connect the cable RJ45 connector to the RJ45 port of the Ethernet switch or router. You can connect more than one inverter to the same switch/router or to different switches/routers, as needed. Each inverter sends its monitored data independently to the SolarEdge monitoring platform.
9. The inverter is configured by default to LAN. If reconfiguration is required:
  - a. Make sure the ON/OFF switch is OFF.
  - b. Turn ON the AC to the inverter by turning ON the circuit breaker on the main distribution panel.
  - c. Use the internal user buttons to configure the connection, as described in *Communication* on page 36.

#### NOTE



If your network has a firewall, you may need to configure it to enable the connection to the following address:

- Destination Address: [prod.solaredge.com](https://prod.solaredge.com)
- TCP Port: 22222 (for incoming and outgoing data)

10. Verify the connection, as described in *Verifying the Connection* on page 55.

## Creating an RS485 Bus Connection

The RS485 option enables creating a bus of connected inverters, consisting of up to 31 slave inverters and 1 master inverter. Using this option, inverters are connected to each other in a bus (chain), via their RS485 connectors. The first and last inverters in the chain must be terminated.

RS485 wiring specifications:

- Cable type: Min. 3-wire shielded twisted pair (a shielded Ethernet cable (Cat5/5E STP) may be used))
- Wire cross-section area: 0.2- 1 mm<sup>2</sup>/ 24-18 AWG (a CAT5 cable may be used)

- Maximum nodes: 32
- Maximum distance between first and last devices: 1 km /3300 ft.

**NOTE**

If using a cable longer than 10 m / 33 ft in areas where there is a risk of induced voltage surges by lightning, it is recommend to use external surge protection devices. For details refer to:

[http://www.solaredge.com/files/pdfs/lightning\\_surge\\_protection.pdf](http://www.solaredge.com/files/pdfs/lightning_surge_protection.pdf).

If not using surge protection, connect the grounding wire to the first inverter in the RS485 chain; make sure the grounding wire is not in contact with other wires. For inverters with a DC Safety Switch, connect the grounding wire to the grounding bus-bar in the DC Safety Switch.

**NOTE**

An additional RS485 port (RS485-E) is available from SolarEdge, allowing configuration of multiple RS485 buses for communications in large sites; Refer to [http://www.solaredge.com/files/pdfs/RS485\\_expansion\\_kit\\_installation\\_guide.pdf](http://www.solaredge.com/files/pdfs/RS485_expansion_kit_installation_guide.pdf).



The following sections describe how to physically connect the RS485 bus and how to configure the bus.

► **To connect the RS485 communication bus:**

1. Remove the inverter cover as described in *Removing the Inverter Cover* on page 49.
2. Remove the seal from one of the openings in communication gland #2 and insert the wire through the opening.
3. Pull out the 9-pin RS485/RS232 terminal block connector, as shown below:

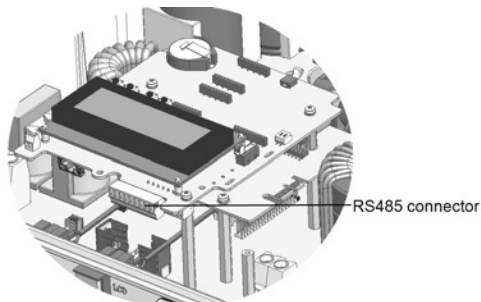

**Figure 24: The RS485 terminal block**

- Loosen the screws of pins A(+), B(-), and G on the left of the RS485 terminal block (RS485-1).

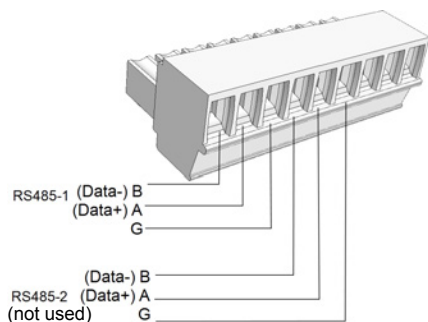

**Figure 25: RS485 terminal block**

- Insert the wire ends into the **G**, **A** and **B** pins shown above. Use Four- or six-wire twisted pair cable for this connection. You can use any color wire for each of the **A**, **B** and **G** connections, as long as the same color wire is used for all A pins, the same color for all B pins and the same color for all G pins.
- For creating an RS485 bus - connect all B, A and G pins in all inverters. The following figure shows this connection schema:

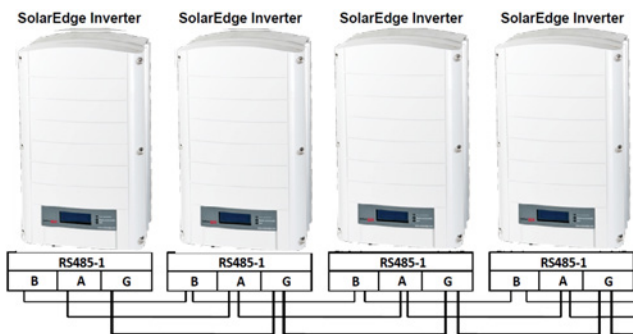

**Figure 26: Connecting the inverters in a chain**



**NOTE**

Do not cross-connect B, A and G wires.

- Tighten the terminal block screws.
- Check that the wires are fully inserted and cannot be pulled out easily.
- Push the RS485 terminal block firmly all the way into the connector on the right side of the communication board.

10. Terminate the first and last SolarEdge device (inverter/SMI/Control and communication gateway, etc.) in the chain by switching a termination DIP-switch inside the inverter to ON (move the left switch up). The switch is located on the communication board and is marked SW7.

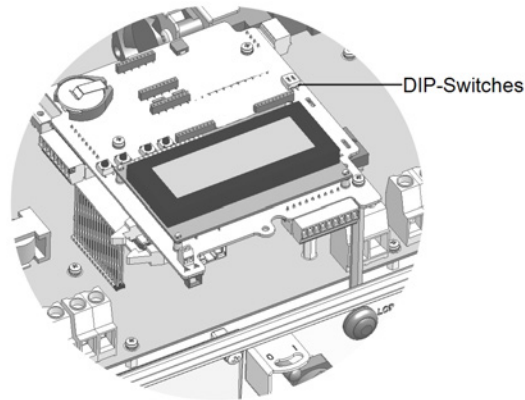

Figure 27: RS485 termination switch



#### NOTE

Only the first and last SolarEdge devices in the chain should be terminated. The other inverters in the chain should have the termination switch OFF (down position).

11. If not using surge protection, connect the grounding wire to the first inverter in the RS485 chain; make sure the grounding wire is not in contact with other wires. For inverters with a DC Safety Switch, connect the grounding wire to the grounding bus-bar in the DC Safety Switch.

#### ► To connect to the monitoring platform:

1. Designate a single inverter as the connection point between the RS485 bus and the SolarEdge monitoring platform. This inverter will serve as the master inverter.
2. Connect the master to the SolarEdge monitoring platform via the LAN or ZigBee communication option.

#### ► To configure the RS485 communication bus:

All inverters are configured by default as slaves. If reconfiguration is required:

1. Make sure the ON/OFF switch is OFF.
2. Turn ON the AC to the inverter by turning ON the circuit breaker on the main distribution panel.



#### WARNING!

ELECTRICAL SHOCK HAZARD. Do not touch uninsulated wires when the inverter cover is removed.

3. Use the internal buttons to configure the connection. To set the inverter designated as master, select the following in the LCD menus:
  - Communication → Server → LAN, ZigBee or Wi-Fi
  - RS485-1 Conf. → Device Type → SolarEdge
  - RS485-1 Conf. → Protocol → Master
  - RS485-1 Conf. → Slave Detect

The system starts automatic detection of the SolarEdge slave inverters connected to the master inverter. The inverter should report the correct number of slaves. If it does not, verify the connections and terminations.

4. Verify the connection of the master to the SolarEdge monitoring platform, as described in *Verifying the Connection* on page 55.

## Verifying the Connection

After connecting and configuring a communication option, perform the following steps to check that the connection to the monitoring server has been successfully established.

1. Close the inverter cover: Attach the inverter cover and secure it by tightening the screws with a torque of 9.0 N\*m/ 6.6 lb.\*ft. For proper sealing, first tighten the corner screws and then the two central screws (see also *Figure 16*).
2. Turn ON the AC to the inverter by turning ON the circuit breaker on the main distribution panel and turning on the (if applicable).
3. Wait for the inverter to connect to the SolarEdge monitoring platform. This may take up to two minutes.

A status screen similar to the following appears on the LCD panel:

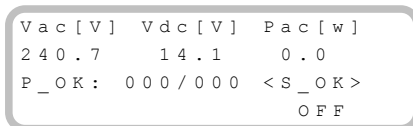

```
V a c [ V ]   V d c [ V ]   P a c [ w ]  
2 4 0 . 7     1 4 . 1     0 . 0  
P _ O K :   0 0 0 / 0 0 0   < S _ O K >  
                                O F F
```

**S\_OK:** Indicates that the connection to the SolarEdge monitoring platform is successful. If S\_OK is not displayed, refer to *Errors and Troubleshooting* on page 56.



## Appendix A: Errors and Troubleshooting

This appendix describes general system problems, and how to troubleshoot them. For further assistance, contact SolarEdge Support.

For information on the error and warning messages that appear on the LCD panel when an error occurs, refer to <http://www.solaredge.com/sites/default/files/se-inverter-installation-guide-error-codes.pdf>.



### Troubleshooting Communication

#### Troubleshooting Ethernet Communication

When using Ethernet communication, use the **Server Communication Status** window to identify the location of the error:

```

Server : LAN    <S_OK>
Status :      <OK>
          xxxxxxxx
<ERROR MESSAGE>
  
```

xxxxxxx is a string of 1s and 0s showing an eight-bit communication connection status. 1 indicates OK and 0 indicates an error.

Bit Location	Error Message	Cause and Troubleshooting
1st	LAN Disconnected	Physical connection fault. Check the cable pin-out assignment and cable connection. Refer to <i>Creating an Ethernet (LAN) Connection</i> on page 49
2nd	DHCP Failed, or Invalid DHCP Config	IP settings issue. Check the router and inverter configuration. Consult your network IT.
3rd	Gateway Ping Failed	Ping to router failed. Check the physical connection to the switch/router. Check that the link LED at the router /switch is lit (indicating phy-link). If OK - contact your network IT, otherwise replace the cable or change it from cross to straight connection.

Bit Location	Error Message	Cause and Troubleshooting
4th	G Server Ping Failed	Ping to google.com failed. Connect a laptop and check for internet connection. If internet access is unavailable, contact your IT admin or your internet provider. For Wi-Fi networks, ensure that username and password are as defined in the internet provider AP/router.
5th	Server x Ping Failed	Ping or connection to SolarEdge server failed. Check the SolarEdge server address, under <b>LAN Conf</b> submenu: Address: prod.solaredge.com Port: 22222
6th		Check with your network administrator whether a firewall or another device is blocking transmission.
7th		
8th	Tcp Connect. Failed	

1. If the message **Master Not Found** appears, check the connections to the master device and fix if required.
2. If after slave detection the number of slaves displayed in the master under **RS485-X Conf** → **Slave Detect** is smaller than the actual number of slaves, use the slave list to identify missing slaves and troubleshoot connectivity problems:
  - a. Select **RS485-X Conf** → **Slave List**. A list showing the serial numbers of the detected slaves is displayed.
  - b. To view the details of a detected slave device, select its serial number entry.

```

ID: 5000FE01-4F
Last Communication
17/02/2015
14:24:01
```

- **ID:** Serial number
- **Last Communication:** date and time (dd:mm:yy 24h) of last communication with the master. If this device is detected for the first time after the master wakeup, **N/A** appears for this information.

## Additional Troubleshooting

1. Check that the modem or hub/router is functioning properly.
2. Check that the connection to the internal connector on the communication board is properly done.
3. Check that the selected communication option is properly configured.
4. Use a method independent of the SolarEdge device to check whether the network and modem are operating properly. For example, connect a laptop to the Ethernet router and connect to the Internet.
5. Check whether a firewall or another type of network filter is blocking communication.

## Power Optimizer Troubleshooting

If the inverter status screen indicates that not all power optimizers are paired or not all are reporting (P\_OK xxx/yyy, and x<y), those optimizers can be identified through the LCD. Refer to [http://www.solaredge.com/sites/default/files/non\\_reporting\\_power\\_optimizers.pdf](http://www.solaredge.com/sites/default/files/non_reporting_power_optimizers.pdf)



Problem	Possible cause and troubleshooting
Pairing failed	Power optimizers are shaded. If you connected the inverter to the SolarEdge monitoring platform, retry pairing remotely (during sunlight). Make sure to leave the inverter ON/OFF switch ON and that S_OK appears on the LCD..
String voltage is 0V	Power optimizer(s) output is disconnected. Connect all power optimizer outputs
String voltage not 0V but lower than number of optimizers	Power optimizer(s) not connected in the string. Connect all power optimizers
	Module(s) not connected properly to power optimizer inputs (not applicable to smart modules). Connect the modules to the optimizer inputs
	String reverse polarity. Check string polarity using a voltmeter and correct if needed.
	Extra power optimizer(s) connected in the string (not applicable to smart modules). Check if an extra power optimizer is connected in the string. If not – proceed to next solution.
String voltage is higher than the number of optimizers <b>WARNING!</b> If the measured voltage is too high, the installation may not have a safe low voltage. PROCEED WITH CARE! A deviation of $\pm 1\%$ per string is reasonable.	A module is connected directly to the string, without a power optimizer (not applicable to smart modules). Verify that only power optimizers are connected in the string and that no module outputs are connected without a power optimizer. If the problem persists, proceed to the next step.
	Power optimizer(s) malfunction. <ul style="list-style-type: none"> <li>o Disconnect the wires connecting the power optimizers in the string.</li> <li>o Measure the output voltage of each power optimizer to locate the power optimizer that does not output 1V safety voltage. If a malfunctioning power optimizer is located, check its connections, polarity, module, and voltage.</li> <li>o Do not continue before finding the problem and replacing the malfunctioning power optimizer. If a malfunction cannot be bypassed or resolved, skip the malfunctioning power optimizer, thus connecting a shorter string.</li> </ul>

## Appendix B: Mechanical Specifications

The following figures provide dimensions of the mounting brackets for the single and three phase inverters.

### Single Phase Inverter and Mounting Bracket

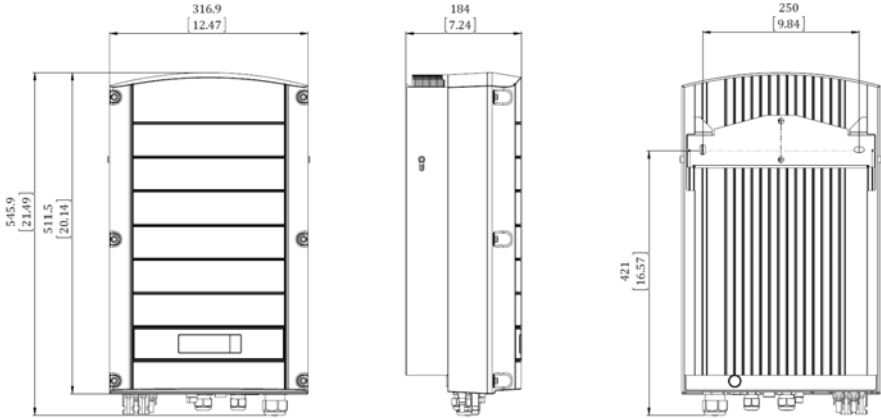

Figure 28: Single phase inverter with bracket - front, side and rear views

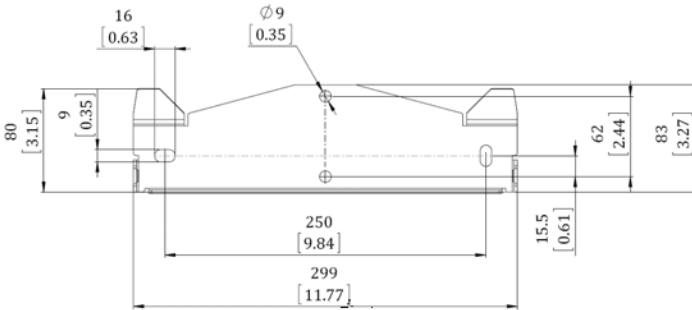

Figure 29: Inverter mounting bracket

# Three Phase Inverter and Mounting Bracket

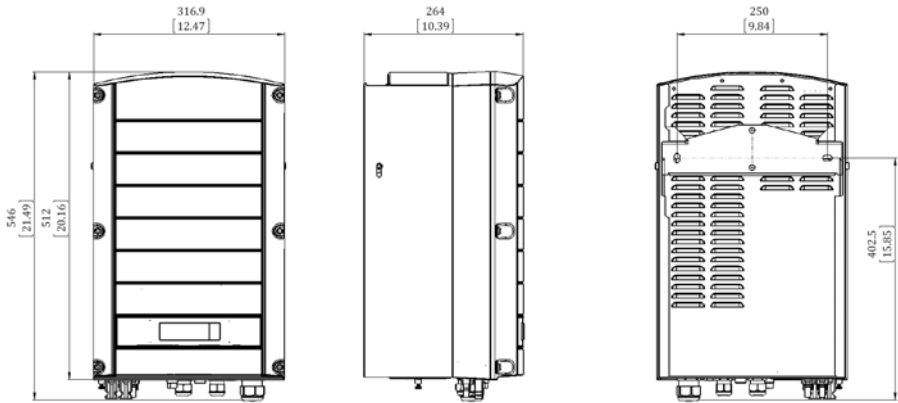

Figure 30: Three phase inverter with bracket - front, side and rear views

## Appendix C: Connecting the AC and DC Strings to the DC Safety Unit

Some inverter models are supplied with an integrated DC Safety Unit. This appendix describes how to connect the AC grid and DC strings to the DC Safety Unit.

Extended power three phase inverters (SE25K - SE33.3K) can be supplied with an optional integrated DC Safety Unit. The DC Safety Unit includes:

- Mechanical DC switch (2-pole disconnection)
- DC surge protection (SPD, Type II)
- DC fuses (plus & minus; optional)

This appendix describes connections to DC Safety Unit with or without fuses. The following figure illustrates the DC Safety Unit supplied with fuses.

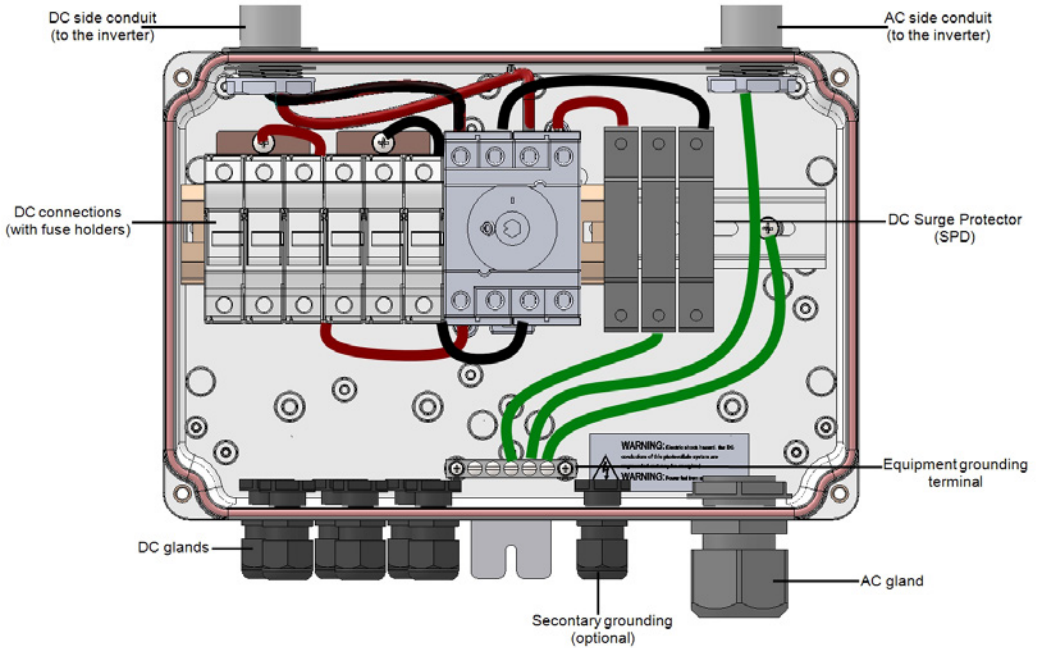

Figure 31: Inside the DC Safety Unit with fuses

## Connecting the AC Grid to the Inverter

Use a five-wire cable for this connection. The maximum wire size for the input terminal blocks is 16mm<sup>2</sup>.

### ▶ To connect the AC grid to the inverter via the DC Safety Unit:

- Turn OFF the following:
  - The inverter ON/OFF switch
  - The AC circuit breaker
  - The DC Safety Unit
- Open the inverter cover: Release the Allen screws and carefully move the cover horizontally before lowering it.



#### CAUTION!

When removing the cover, make sure not to damage internal components. SolarEdge will not be held responsible for any components damaged as a result of incautious cover removal.

- Loosen the screws on the front cover of the DC Safety Unit, as shown below:

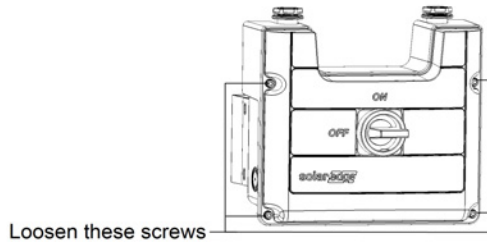

Figure 32: Opening the DC Safety Unit cover

- Remove the DC Safety Unit cover.
- Strip 35 cm of the external cable insulation and strip 8 mm of the internal wire insulation.

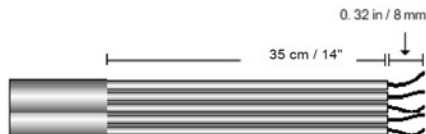

Figure 33: Insulation stripping – AC

- Open the AC cable gland and insert the cable through the gland (see *Figure 31*).
- Connect the grounding wire to the equipment grounding terminal in the DC Safety Unit.



#### NOTE

Connect the equipment grounding before connecting the AC wires to the AC terminal block.

- Insert the remaining four wires through the AC conduit to the inverter, and connect them to the appropriate terminal blocks in the inverter according to the labels on the terminal blocks (N, L1, L2 and L3).

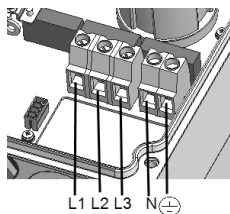

**Figure 34: Three Phase Inverter AC Terminals**

- Tighten the screws of each terminal with a torque of 1.2-1.5 N\*m / 0.88-1.1 lb\*ft.
- Check that the wires are fully inserted and cannot be pulled out easily.
- Tighten the AC cable gland with a torque of 2.8-3.3 N\*m / 2.0-2.4 lb\*ft.
- Verify that there are no unconnected wires.
- Make sure the SPDs are tightly attached to the DIN rail.

#### NOTE



If power control is enabled, it is important to respect the order of grid lines connection to the inverter. A 120deg phase difference should be kept between L1 to L2 and between L2 to L3 (L1-L2-L3 and not, for example L1-L3-L2).

If the grid lines are not in this order, an error is displayed on the LCD and the inverter will not produce power.

## Connecting the Strings to the DC Safety Unit

Up to three strings may be connected in parallel to the DC input pairs of the switch. The terminals are suitable for connection of copper conductors only.

### ► To connect the strings to the DC Safety Unit:

- Strip 8 mm of the DC wire insulation.
- Insert the wires into the DC input glands of the DC Safety Unit .



3. Connect the DC wires according to the DC+ and DC- labels:

- For DC terminals *without fuses*: Use a standard flat-blade screwdriver to connect the wires to the spring-clamp terminals.
  - The screwdriver blade should fit freely in the terminal opening. Too large a blade can crack the plastic housing.
  - Insert the screwdriver and press the release mechanism and open the clamp.
  - Insert the conductor into the round opening and remove the screwdriver – the wire is automatically clamped.

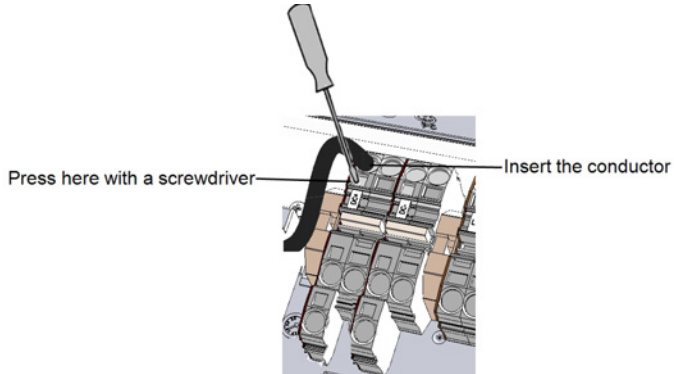

**Figure 35: Spring-clamp terminals**

- For DC terminals *with fuses*:
  - Insert the wires into the side openings.
  - Fasten the screws at the top of the fuses.

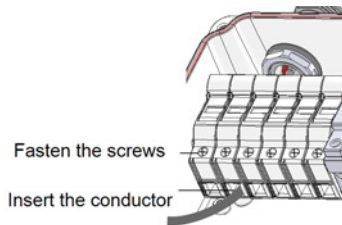

**Figure 36: DC connection with fuses**

4. Verify that there are no unconnected wires.
5. Close the DC Safety Unit cover: Attach the cover and secure it by tightening the four screws with a torque of 1.2 N\*m / 0.9 ft. \*lb.
6. Ensure proper cable entry sealing: inspect the entire cable run and use standard sealants to avoid water penetration.

## Appendix D: SafeDC™

When AC supply to the inverter is shut off (by shutting off the AC breaker at the site), or when the inverter ON/OFF switch is turned to OFF, the DC voltage drops to a safe voltage of 1V per optimizer.

The SolarEdge inverters are certified for compliance with the following standards as disconnection devices for PV generators, meaning that they can replace a DC disconnect:

- IEC 60947-3:1999 + Corrigendum: 1999 + A1:2001 + Corrigendum 1:2001 + A2:2005;
- DIN EN 60947-3
- VDE 0660-107:2006-03
- IEC 60364-7-712:2002-05
- DIN VDE 0100-712:2006-06.

In compliance with these standards, the disconnection mechanism operates as follows:

1. Turn the inverter ON/OFF switch, located at the bottom of the inverter, to OFF, or disconnect the AC by shutting off the AC breaker at the site. The DC voltage displayed on the inverter LCD begins to decrease.

If the AC breaker was shut off, the LCD does not display. In this case, wait five minutes.

2. When the DC voltage reaches a safe voltage, the PV connectors at the input to the inverter can be disconnected. A galvanic separation then exists between the PV array and the inverter.

### WARNING!

SafeDC complies with IEC60947-3 when installing the system with a worst case SafeDC voltage (under fault conditions) < 120V.



The worst case voltage is defined as:  $V_{oc,max} + (\text{String Length} - 1) * 1V$ , where:

- $V_{oc,max}$  = Maximum Voc (at lowest temperature) of the PV module in the string (for a string with multiple module models, use the max value)
- String Length = number of power optimizers in the string

## Appendix E: External Fan Maintenance and Replacement

Some inverters have two fans: one is internal and requires a SolarEdge technician to replace and the other is accessible from the outside of the inverter.

A fan replacement kit is available from SolarEdge.

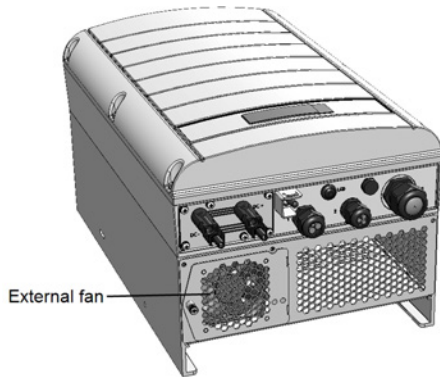

Figure 37: Inverter external fan

### Fan Maintenance

1. At least once a year, open the fan screen and clean the accumulated dust using a brush.
2. Check the Fan Status screen on the LCD (refer to *Fan Status* on page 45).
3. If one of the following occurs, replace the fan as described below:
  - When the fan stops operating
  - Fan status is **Not Working**; Before replacing the fan, turn the inverter AC OFF and ON and check if the status is cleared
  - The following Error is displayed:

Fan 2 Failure

### External Fan Replacement

1. Turn OFF the inverter ON/OFF switch, and wait until the LCD indicates that the DC voltage is safe (<50V), or wait five minutes before continuing to the next step.



#### WARNING!

If you cannot see the inverter panel, or if a malfunction is indicated on the LCD panel, wait five minutes for the input capacitors of the inverter to discharge.

2. Turn OFF the Safety Switch and the AC switch of the distribution panel.
3. Use a Phillips screwdriver to unfasten the single screw of the fan cover.
4. Open the fan door.

5. Disconnect the fan connector and remove the fan.

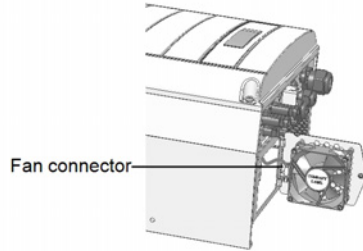

**Figure 38: Fan connector**

6. Connect the fan connector to the new fan.
7. Close the fan door and fasten the cover screw.
8. Check the *Fan Status* on page 45.

## Appendix F: Replacing and Adding System Components



### NOTE

If you are permanently disassembling the installation or part of it, make sure to use the disposal methods dictated by local regulations.

### CAUTION!



Do not remove the six screws on the DC metal panel as it may harm the inverter sealing and void the warranty.

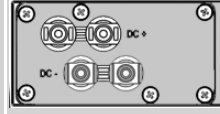

## Replacing an Inverter

1. Turn OFF the inverter ON/OFF switch, and wait until the LCD indicates that the DC voltage is safe (<50V), or wait five minutes before continuing to the next step.



### WARNING!

If you cannot see the inverter panel, or if a malfunction is indicated on the LCD panel, wait five minutes for the input capacitors of the inverter to discharge.

2. Open the inverter cover as described in *Removing the Inverter Cover* on page 49.
3. Disconnect the DC plugs and AC wires from the inverter.
4. For inverters with a Safety Switch, unscrew the two conduit nuts in the inverter securing the Safety Switch to the inverter.

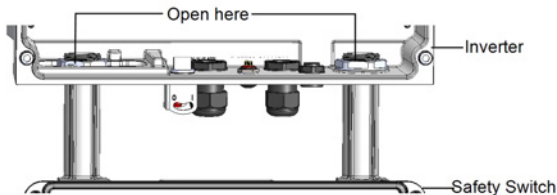

Figure 39: Conduit nuts

5. Remove the screws securing the inverter to the mounting bracket and remove the inverter from the mounting bracket.



### NOTE

If you remove the old inverter and do not immediately install a new one, use insulation tape to isolate each of the AC and DC wires

6. Place the new inverter on the mounting bracket; insert the screws securing the inverter to the mounting bracket.
7. Connect the DC and AC wires to the inverter.
8. Follow the instructions of *Installing the Inverter* on page 15 and *Commissioning the Installation* on page 25.

## Replacing the DC Safety Unit

### Removing the DC Safety Unit

1. Turn OFF the inverter ON/OFF switch, and wait until the LCD indicates that the DC voltage is safe (<50V), or wait five minutes before continuing to the next step.



#### WARNING!

If you cannot see the inverter panel, or if a malfunction is indicated on the LCD panel, wait five minutes for the input capacitors of the inverter to discharge.

2. Turn OFF the Safety Switch and the AC switch of the distribution panel.
3. Open the inverter cover.
4. Disconnect the DC and AC wires from the inverter. If there are ferrite beads on the DC and AC wires in the inverter, open them and set aside.
5. Disconnect the RS485 connector from the inverter communication board.
6. Unscrew the two conduit nuts in the inverter securing the DC Safety Unit to the inverter.
7. Open the DC Safety Unit cover and disconnect the DC and AC wires. Unscrew the two conduit nuts securing the DC Safety Unit to the external conduits.
8. If the DC Safety Unit bracket is screwed to the wall, release it.
9. Carefully remove the DC Safety Unit with its mounting bracket from the wall.

### Installing a New DC Safety Unit

1. Open the conduit knockouts of the new DC Safety Unit .
2. Position the new DC Safety Unit below the inverter and from the inside of the inverter grab the AC and DC wires extending from the switch conduits, as shown below:

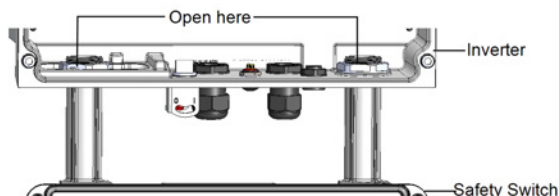

**Figure 40: Inserting the AC and DC conduits**

3. Attach the DC Safety Unit with its bracket to the wall and slightly close the screws. Do not over tighten.
4. Securely screw the two conduit nuts onto the conduit ends in the inverter. Verify proper conduit sealing.

### Connecting the Safety Switch to the Inverter

1. If ferrite beads were removed from the DC and AC wires, place them on the wires and close them. Make sure the DC labeled ferrite bead is placed on the DC wires and the AC labeled ferrite bead is placed on the AC wires.
2. Connect the DC, as follows:

- Connect the red wire to any of the DC+ terminals in the inverter.
- Connect the black wire to any of the DC- terminals in the inverter.

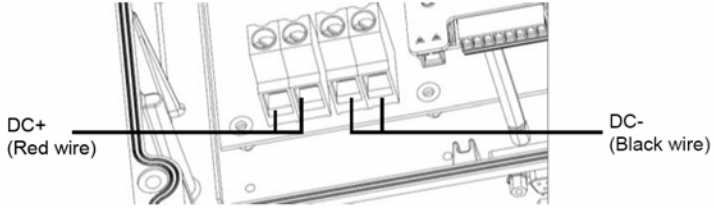

**Figure 41: Single phase 3-7.6kW inverter DC terminals**

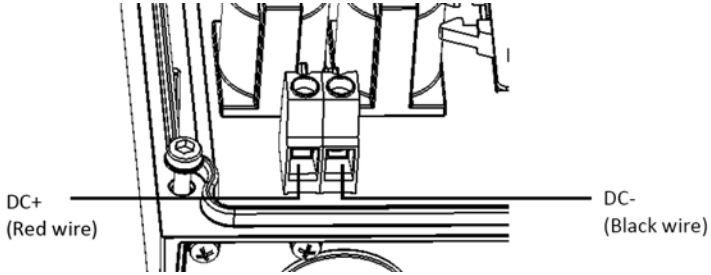

**Figure 42: Single phase 10-11.4 kW inverter DC terminals**

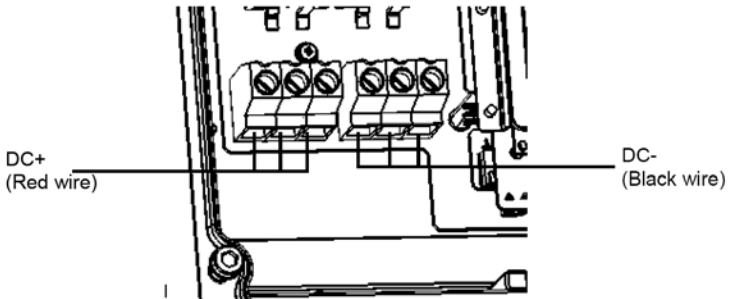

**Figure 43: Three phase inverter DC terminals**

3. Connect the AC wires according to the labels on the AC terminal blocks, as follows:

Single Phase Inverter	
Wire type	Connect to terminal
PE (grounding)	Ground 
Line	Line
Neutral	N

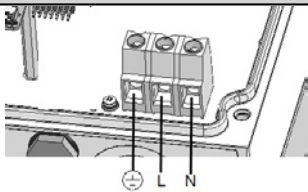

**Figure 44: Single phase inverter AC terminals**

Three Phase Inverter	
Wire type	Connect to terminal
Line 1	L1
Line 2	L2
Line 3	L3
PE (grounding)	
Neutral	N

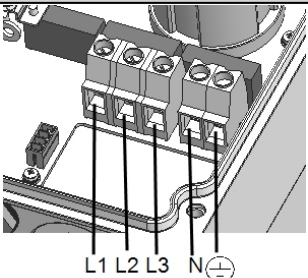

**Figure 45: Three phase inverter AC terminals**

- Tighten the screws of each terminal with a torque of 1.2-1.5 N\*m / 0.88-1.1 lb.\*ft.
- If you replaced a DC Safety Unit with a built-in electricity meter, connect the RS485 connector from the electricity meter to the inverter communication board.
- Verify that there are no unconnected wires at the output of the DC Safety Unit and that any unused terminal screws are tightened.
- Connect the DC and AC wires to the DC Safety Unit. Refer to *Connecting the AC and the Strings to the Inverter* on page 21.
- Ensure proper cable entry sealing; inspect the entire cable run and use standard sealants to avoid water penetration.



## Adding, Removing, or Replacing Power Optimizers

---

1. Turn OFF the inverter ON/OFF switch, and wait until the LCD indicates that the DC voltage is safe (<50V), or wait five minutes before continuing to the next step.

**WARNING!**

If you cannot see the inverter panel, or if a malfunction is indicated on the LCD panel, wait five minutes for the input capacitors of the inverter to discharge.

2. Turn OFF the AC switch of the main distribution panel.
3. Disconnect and connect the necessary power optimizers.
4. Perform pairing and other procedures described in *Commissioning the Installation* on page 25 on all inverters to which power optimizers were added or from which power optimizers were removed.
5. In the monitoring platform, replace the serial number of the removed power optimizer with serial number of the newly installed power optimizer.

# Technical Specifications - Single Phase Inverters

	SE2200	SE3000	SE3500	SE4000	SE4000-16A	SE5000	SE6000	Unit
<b>Output</b>								
Rated AC power output	2200	3000	3500	4000	4000	5000 <sup>1</sup>	6000	VA
Maximum AC power output	2200	3000	3500	4000	4000	5000 <sup>1</sup>	6000	VA
AC output voltage (nominal)	220/230/240							Vac
AC output voltage range	184 – 264.5							Vac
AC frequency(nominal)	50/60 ±5							Hz
Maximum continuous output current	12	16.5 <sup>2</sup>	19.5 <sup>2</sup>	22	16	27	27	A
Max. continuous overcurrent protection	12	16.5 <sup>2</sup>	19.5 <sup>2</sup>	22	16	27	27	A
Residual current detector/ Residual current step detector	300/ 30							mA
Inrush current AC (Peak/Duration)	2.8/ 20							Aac (rms) / ms
Max. output fault current	38							A
Power factor range	1 (adjustable from -0.9 to +0.9)							
Total harmonic distortion	< 3%							
Protective class	Class I							
Utility monitoring, islanding protection, country configurable thresholds	Yes							
Overvoltage category	III							

<sup>1</sup>Limited to 4600VA when the inverter is set to South Africa.

<sup>2</sup>16A when the country is set to Denmark, Portugal, UK, or Poland. For other countries, contact SolarEdge.

	SE2200	SE3000	SE3500	SE4000	SE4000-16A	SE5000	SE6000	Unit
<b>Input</b>								
Maximum DC power (Module STC)	2950	4050	4700	5400	5000	6750	8100	W
Transformer-less, ungrounded	Yes							
Maximum input voltage	500							Vdc
Nominal DC input voltage	350							Vdc
Maximum input current	8.5	11.5	13.5	15.5	15.5	19.5	23	Adc
Maximum back-feed current	0							Adc
Reverse-polarity protection	Yes							
Ground-fault isolation detection	600 kΩ Sensitivity							
Overvoltage category	III							
Maximum inverter efficiency	97.6							%
European weighted efficiency	97.6	97.6	97.5	97.5	97.5	97.4	97.4	%
Night-time power consumption	<2.5							W
<b>Additional Features</b>								
Supported communication interfaces <sup>1</sup>	RS485, RS232, Ethernet, ZigBee (optional), Built-in GSM (optional)							
Smart Energy Management	Export Limitation, StorEdge applications							
<b>Standard Compliance</b>								
Safety	IEC-62103 (EN50178), IEC-62109							
Grid connection standards	VDE-AR-N-4105, VDE 0126-1-1, AS-4777, RD-1663, DK 5940							
Emissions	IEC61000-6-2, IEC61000-6-3, IEC61000-3-11, IEC61000-3-12, FCC part 15 class B							
RoHS	Yes							

<sup>1</sup> Refer to Datasheets -> Communications category in Downloads page for specifications of optional communication options: <http://www.solaredge.com/groups/support/downloads>

	SE2200	SE3000	SE3500	SE4000	SE4000-16A	SE5000	SE6000	Unit	
<b>Installation Specifications</b>									
AC output	Cable Gland - diameter 9-16							mm	
DC input	1 MC4 pair			2 MC4 pairs					
Dimensions (W x L x H)	540 x 315 x 172			540 x 315 x 191					mm
Weight	20.2			21.7					kg
Cooling	Natural Convection								
Noise (typical)	< 50							dB(A)	
Operating temperature range <sup>1</sup>	-20 - +50 (M40 version -40 to + 50)							°C	
Maximum altitude	2000							m	
Operating humidity – non condensing	< 95							%	
Protection Rating / Environmental category	IP65 – Outdoor and Indoor								
Pollution degree classification (inside / outside)	2/3								
Bracket mounted (bracket provided)									

<sup>1</sup>For inverter power de-rating refer to the application note at the following link: <http://www.solaredge.com/files/pdfs/se-temperature-derating-note.pdf>

Recommended circuit breaker/ fuse size to use at the connection point of the SolarEdge inverter to the grid:

Inverter	Maximum Output Current (A)	Maximum Suggested Fuse Rating (A)
SE2200	12	16
SE3000	16.5	20
SE3500	19.5	25
SE4000	22	25
SE4000-16A	16	20
SE5000	27	32
SE6000	27	32



# Technical Specifications - Three Phase Inverters

## SE4K - SE12.5K

	SE4K	SE5K	SE7K	SE8K	SE9K	SE10K	SE12.5K	Unit
<b>Output</b>								
Rated AC power output	4000 <sup>1</sup>	5000 <sup>2</sup>	7000	8000	9000	10000	12500	VA
Maximum AC power output	4000	5000 <sup>2</sup>	7000	8000	9000	10000	12500	VA
AC output voltage – line to line / line to neutral (nominal)	380/ 220; 400/ 230							Vac
AC output voltage range	184 – 264.5							Vac
AC frequency	50/60 ± 5							Hz
Maximum continuous output current (per phase)	6.5	8	11.5	13	14.5	16	20	A
Maximum continuous overcurrent protection	6.5	8	11.5	13	14.5	16	20	A
Residual current detector / Residual Current step detector	300 / 30							mA
Grid supported – three phase	3 / N / PE (WYE with Neutral)							
Inrush current AC (Peak/Duration)	3/ 20							Aac(rms) / ms
Maximum output fault current	33							
Power factor range	1 (adjustable from -0.9 to +0.9)							

<sup>1</sup>SE4K model is available in some countries; refer to the Certifications category in <http://www.solaredge.com/groups/support/downloads>

24985W when the country is set to Australia; 4600W when the country is set to Germany or the Czech Republic.

	SE4K	SE5K	SE7K	SE8K	SE9K	SE10K	SE12.5K	Unit	
Total harmonic distortion	< 3%								
Protective class	Class I								
Utility monitoring, islanding protection, configurable Power Factor, country configurable thresholds	Yes								
Overvoltage category	III								
<b>Input</b>									
Maximum DC power (Module STC)	5400	6750	9450	10800	12150	13500	16850	W	
Transformer-less, ungrounded	Yes								
Maximum input voltage	900								Vdc
Nominal DC input voltage	750								Vdc
Maximum input current	7	8.5	12	13.5	15	16.5	21	Adc	
Maximum back-feed current	0								Adc
Reverse-polarity protection	Yes								
Ground-fault isolation detection	700kΩ Sensitivity								
Overvoltage category	III								
Maximum inverter efficiency	98								%
European weighted efficiency	97.3	97.3	97.3	97.5	97.5	97.6	97.7	%	
Night-time power consumption	< 2.5								W

	SE4K	SE5K	SE7K	SE8K	SE9K	SE10K	SE12.5K	Unit
<b>Additional Features</b>								
Supported communication interfaces <sup>1</sup>	RS485, Ethernet, ZigBee (optional), Wi-Fi (optional), Built-in GSM (optional)							
<b>Standard Compliance</b>								
Safety	IEC-62103 (EN50178), IEC-62109							
Grid connection standards <sup>2</sup>	VDE 0126-1-1, VDE-AR-N-4105, AS-4777, G83 / G59							
Emissions	IEC61000-6-2, IEC61000-6-3, IEC61000-3-11, IEC61000-3-12, FCC part15 class B							
WEEE, RoHS	Yes							
<b>Installation Specifications</b>								
AC output	Cable Gland - diameter 15-21							mm
DC input	2 MC4 pairs							
Dimensions (WxLxH)	540 x 315 x 260							mm
Weight	33.2							kg
Operating temperature range <sup>3</sup>	-20 - +60 (M40 version -40 to + 60)							°C
Operating humidity – non condensing	< 95							%
Cooling	Fan (user replaceable)							

<sup>1</sup> Refer to Datasheets > Communications category in Downloads page for specifications of optional communication options: <http://www.solaredge.com/groups/support/downloads>

<sup>2</sup> For all standards refer to the Certifications category in <http://www.solaredge.com/groups/support/downloads>.

<sup>3</sup> For inverter power de-rating refer to the application note at the following link: <http://www.solaredge.com/files/pdfs/se-temperature-derating-note.pdf>



	SE4K	SE5K	SE7K	SE8K	SE9K	SE10K	SE12.5K	Unit
Noise (typical)	< 50 <sup>1</sup>							dB(A)
Protection rating/ Environmental category	IP65 Outdoor and indoor							
Maximum altitude	2000							m
Pollution degree classification (inside/outside)	2/3							
Bracket mounted (bracket provided)								

## SE15K - SE33.3K<sup>2</sup>

	SE15K	SE16K	SE17K	SE25K	SE27.6K	SE33.3K	Unit
<b>Output</b>							
Rated AC power output	15000	16000	17000	25000	27600	33300	VA
Maximum AC power output	15000	16000	17000	25000	27600	33300	VA
AC output voltage – line to line / line to neutral (nominal)	380/ 220; 400/ 230					480/277	Vac
AC output voltage range	184 – 264.5					244-305	Vac
AC frequency	50/60 ± 5						Hz
Maximum continuous output current (per phase)	23	25.5	26	38	40	40 @277V	A
Maximum continuous overcurrent protection	23	25.5	26	38	40	40	A

<sup>1</sup>For inverters with a noise level suitable for residential environments refer to: <http://www.solaredge.com/files/pdfs/products/inverters/se-three-phase-indoor-inverter-datasheet.pdf>

<sup>2</sup>The SE33.3K model requires a medium voltage transformer.

	SE15K	SE16K	SE17K	SE25K	SE27.6K	SE33.3K	Unit
Residual current detector / Residual Current step detector	300 / 30						mA
Grid supported – three phase	3 / N / PE (WYE with Neutral)						V
Inrush current AC (Peak/Duration)	3/ 20			3.1/ 20		4.2/ 20	Aac(rms)/ ms
Maximum output fault current	40			63			A
Power factor range	1 (adjustable from -0.9 to +0.9)			1 (adjustable from -0.8 to +0.8) <sup>1</sup>			
Total harmonic distortion	< 3%						
Protective class	Class I						
Utility monitoring, islanding protection, configurable Power Factor, country configurable thresholds	Yes						
Overvoltage category	III						
<b>Input</b>							
Maximum DC power (Module STC)	20250	21600	22950	33750	37250	45000	W
Transformer-less, ungrounded	Yes						
Maximum input voltage	900					1000	Vdc
Nominal DC input voltage	750					840	Vdc
Maximum input current	22	23	23	37	40	40	Adc
Maximum back-feed current	0						Adc
Reverse-polarity protection	Yes						

<sup>1</sup>For SE27.6K - when set to Germany Power Factor is limited to 0.9.

	SE15K	SE16K	SE17K	SE25K	SE27.6K	SE33.3K	Unit
Ground-fault isolation detection	700kΩ Sensitivity			350kΩ Sensitivity <sup>1</sup>			
Overvoltage category	III						
Maximum inverter efficiency	98			98.3	98.1		%
European weighted efficiency	97.6	97.7		98			%
Night-time power consumption	< 2.5			< 4			W
<b>Additional Features</b>							
Supported communication interfaces <sup>2</sup>	RS485, Ethernet, ZigBee (optional), Wi-Fi (optional), Built-in GSM (optional)						
<b>DC Safety Unit (optional)</b>							
2-pole Disconnection	N/A			1000V / 40A			
DC Surge Protection	N/A			Type II, field replaceable			
DC Fuses on Plus & Minus	N/A			Optional, 20A			
Compliance	N/A			UTE-C15-712-1			
<b>Standard Compliance</b>							
Safety	IEC-62103 (EN50178), IEC-62109, AS3100						
Grid connection standards <sup>3</sup>	VDE-AR-N-4105, G59/3, AS-4777, EN 50438, VDE 0126-1-1, CEI-021, BDEW <sup>4</sup> , CEI-016 <sup>5</sup> ;						

<sup>1</sup>Where permitted by local regulations

<sup>2</sup>Refer to Datasheets -> Communications category in Downloads page for specifications of optional communication options: <http://www.solaredge.com/groups/support/downloads>

<sup>3</sup>For all standards refer to the Certifications category in <http://www.solaredge.com/groups/support/downloads>.

<sup>4</sup>Models SE25K, SE27.6K and SE33.3K only

<sup>5</sup>Models SE25K, SE27.6K and SE33.3K only

	SE15K	SE16K	SE17K	SE25K	SE27.6K	SE33.3K	Unit
Emissions	IEC61000-6-2, IEC61000-6-3, IEC61000-3-11, IEC61000-3-12						
WEEE, RoHS	Yes						
<b>Installation Specifications</b>							
AC output	Cable Gland - diameter 15-21			Cable Gland - diameter 18-25			mm
DC input	2 MC4 pairs			3 MC4 pairs			
DC input with optional DC safety unit	N/A			Gland outer diameter 5-10 mm			mm
				Wire cross section 0.5 - 13.5			mm <sup>2</sup>
Dimensions (HxWxD)	540 x 315 x 260						mm
Dimensions with Safety Unit (HxWxD)	N/A			775 x 315 x 260			mm
Weight	33.2			45			kg
Weight with Safety Unit	N/A			48			kg
Operating temperature range <sup>1</sup>	-20 - +60 (M40 version -40 to + 60)						°C
Operating humidity – non condensing	< 95						%
Cooling	Fan (user replaceable)						
Noise (typical)	< 50			< 55			dB(A)
Protection rating/ Environmental category	IP65 Outdoor and indoor						
Maximum altitude	2000						m
Pollution degree classification (inside/ outside)	2/3						
Bracket mounted (bracket provided)							

<sup>1</sup>For inverter power de-rating refer to the application note at the following link: <http://www.solaredge.com/files/pdfs/se-temperature-derating-note.pdf>

Recommended circuit breaker/ fuse size to use at the connection point of the SolarEdge inverter to the grid:

Inverter	Maximum output current (A)	Minimum fuse Rating (A)	Maximum fuse rating (A)
SE4K	6.5	10	33
SE5K	8	10	33
SE7K	11.5	16	33
SE8K	13	20	33
SE9K	14.5	20	30
SE10K	16	20	30
SE12.5K	20	25	30
SE15K	23	32	40
SE16K	25.5	32	40
SE17K	26	32	40
SE25K	38	50	63
SE27.6K	40	50	63
SE33.3K	40	50	63

## DC Safety Unit Specifications (Optional - SE25K-SE33.3K)

	Specification
2-pole Disconnection	1000V / 40A
DC Surge Protection	Type II, field replaceable
DC Fuses on Plus & Minus	Optional, 20A
Weight	2.7 kg
Compliance	UTE-C15-712-1
Protective Class	Class II



# Technical Specifications - E-Series Three Phase Inverters

## SE4K - SE8K

	SE4K	SE5K	SE7K	SE8K	Unit
<b>Output</b>					
Rated AC power output	4000 <sup>1</sup>	5000 <sup>2</sup>	7000	8000	VA
Maximum AC power output	4000	5000 <sup>2</sup>	7000	8000	VA
AC output voltage – line to line / line to neutral (nominal)	380/220; 400/230				Vac
AC output voltage range	184 – 264.5				Vac
AC frequency	50/60 ± 5				Hz
Maximum continuous output current (per phase)	6.5	8	11.5	13	A
Maximum continuous overcurrent protection	6.5	8	11.5	13	A
Residual current detector / Residual Current step detector	300 / 30				mA
Grid supported – three phase	3 / N / PE (WYE with Neutral)				
Inrush current AC (Peak/Duration)	3/20				Aac(rms) / ms
Maximum output fault current	33				
Power factor range	1 (adjustable from -0.9 to +0.9)				
Total harmonic distortion	<3%				
Protective class	Class I				
Utility monitoring, islanding protection, configurable Power Factor, country configurable thresholds	Yes				
Overvoltage category	III				
<b>Input</b>					
Maximum DC power (Module STC)	5400	6750	9450	10800	W
Transformer-less, ungrounded	Yes				
Maximum input voltage	900				Vdc
Nominal DC input voltage	750				Vdc
Maximum input current	7	8.5	12	13.5	Adc
Maximum back-feed current	0				Adc
Reverse-polarity protection	Yes				
Ground-fault isolation detection	700kΩ Sensitivity				
Overvoltage category	III				
Maximum inverter efficiency	98				%
European weighted efficiency	97.3	97.3	97.4	97.6	%
Night-time power consumption	<2.5				W
<b>Additional Features</b>					
Supported communication interfaces <sup>3</sup>	RS485, Ethernet, ZigBee (optional), Wi-Fi (optional), Built-in GSM (optional)				
<b>Standard Compliance</b>					
Safety	IEC-62103 (EN50178), IEC-62109				
Grid connection standards <sup>4</sup>	VDE 0126-1-1, VDE-AR-N-4105, AS-4777, G83 / G59				
Emissions	IEC61000-6-2, IEC61000-6-3, IEC61000-3-11, IEC61000-3-12, FCC part 15 class B				
WEEE, RoHS	Yes				
<b>Installation Specifications</b>					
AC output	Cable Gland - diameter 15-21				mm
DC input	2 MC4 pairs				
Dimensions (WxLxH)	540 x 315 x 191				mm

<sup>1</sup>SE4K model is available in some countries; refer to the Certifications category in <http://www.solaredge.com/groups/support/downloads>

24985W when the country is set to Australia; 4600W when the country is set to Germany or the Czech Republic.

<sup>3</sup>Refer to Datasheets > Communications category in Downloads page for specifications of optional communication options: <http://www.solaredge.com/groups/support/downloads>

<sup>4</sup>For all standards refer to the Certifications category in <http://www.solaredge.com/groups/support/downloads>.

	SE4K	SE5K	SE7K	SE8K	Unit
Weight	21.7				kg
Operating temperature range <sup>1</sup>	-20 - +60 (M40 version -40 to + 60)				°C
Operating humidity – non condensing	< 95				%
Cooling	Natural convection and internal fan (user replaceable)				
Noise (typical)	< 40				dBA
Protection rating/ Environmental category	IP65 Outdoor and indoor				
Maximum altitude	2000				m
Pollution degree classification (inside/outside)	2/3				
Bracket mounted (bracket provided)					

Recommended circuit breaker/fuse size to use at the connection point of the SolarEdge inverter to the grid:

Inverter	Maximum output current (A)	Minimum fuse Rating (A)	Maximum fuse rating (A)
SE4K	6.5	10	33
SE5K	8	10	33
SE7K	11.5	16	33
SE8K	13	20	33

<sup>1</sup>For inverter power de-rating refer to the application note at the following link: <http://www.solaredge.com/files/pdfs/se-temperature-derating-note.pdf>

If you have technical queries concerning our products,  
please contact our support through SolarEdge service portal:  
<http://www.solaredge.com/groups/support/services>

Australia (+61)	1800-465-567
Belgium (+32)	0800-78889
China(+86)	186-0166-3934
France (+33)	0800-917410
Germany (+49)	089-45459730
Italy (+39)	800-784-824
Japan (+81)	03-6261-1274
United Kingdom (+44)	0800-028-1183
US & Canada (+1)	510-498-3200
Greece (+30)	00800-125574
Israel (+972)	073-240-3122
Netherlands (+31)	0800-022-1089
New Zealand (+64)	0800 144 875
Worldwide (+972)	073-2403118
Fax (+972)	073-240-3117
Email to:	<a href="mailto:support@solaredge.com">support@solaredge.com</a>

**solar**edge

[www.solaredge.com](http://www.solaredge.com)