

# User Manual

## HV2600

In order to prevent improper operation before use, please carefully read this manual.

# Table of Contents

1. Introduction .....	1
2. Symbols .....	1
3. Safety .....	2
3.1 Handling .....	2
3.2 Installation .....	2
4. Response to Emergency Situations .....	3
4.1 Warning Labels .....	3
5. Product Information .....	4
5.1 Battery Module Specifications .....	4
5.2 BMS Specifications .....	4
5.3 Battery System Specifications .....	5
6. Product Features .....	6
6.1 Battery System Features .....	6
7. Installation .....	9
7.1 Items in the package .....	9
7.2 Clearance .....	10
7.3 Tools .....	10
7.4 Installation Steps .....	11
7.5 Wiring Steps .....	13
7.6 System Start up .....	15
8. Commissioning .....	15
9. Exclusion .....	17
10. Troubleshooting and Maintenance .....	17
10.1 Maintenance .....	17
10.2 Troubleshooting .....	17

# 1. Introduction

The document describes the installation, commissioning, maintenance and troubleshooting of the following high voltage battery listed below.

HV2600

Note: HV2600 = 2.6kWh High Voltage

The battery chemistry of these products is Lithium Iron Phosphate. This manual is designed for qualified personnel only. The tasks described in this document should be performed by authorized and qualified technicians only.

After installation the Installer must explain the user manual to the end user.

# 2. Symbols

	Caution, risk of electric shock.
	Do not place nor install near flammable or explosive materials.
	Install the product out of reach of children.
	Read the instruction manual before starting installation and operation.
	Do not dispose of the product with household wastes.
	Recyclable.
	Disconnect the equipment before carrying out maintenance or repair.
	Observe precautions for handling electrostatic discharge sensitive devices.
	Protective Class 1.
	Caution, risk of electric shock, energy storage timed discharge.

## 3. Safety

Any work on the Batteries should be handled by authorized technicians and hence it is understood that the technicians should familiarize themselves with the contents of this manual before any maintenance or installation is carried out on the system.

### 3.1 Handling

- Do not expose battery to open flame.
- Do not place the product under direct sunlight.
- Do not place the product near flammable materials. It may lead to fire or explosion in case of accident.
- Store in a cool and dry place with ample ventilation.
- Do not store the product near water sources.
- Store the product on a flat surface.
- Store the product out of reach of children and animals.
- Do not damage the unit by dropping, deforming, impacting, cutting or penetrating with a sharp object. It may cause leakage of electrolyte or fire.
- Do not touch any liquid spilled from the product. There is a risk of electric shock or damage to skin.
- Always handle the battery wearing the insulated gloves.
- Do not step on the product or place any foreign objects on it. This can result in damage.
- Do not charge or discharge damaged battery.
- Do not store the battery near water sources.

### 3.2 Installation

- Do not connect the HV2600 to inverter conductors or Photo-Voltaic conductors. This will damage the battery and may result in explosion.
- After unpacking, please check the product for damages and missing parts.
- Make sure that the inverter and battery is completely turned off before commencing installation.
- Do not interchange the positive and negative terminals of the battery.
- Ensure that there is no short circuit of the terminals or with any external device.
- Do not exceed the battery voltage rating of the inverter.
- Do not connect the battery to any incompatible inverter.
- Do not connect different battery types together.
- Please ensure that all the batteries are grounded properly.
- Do not open the battery to repair or disassemble. Only Fox is allowed to carry out any such repairs.
- In case of fire, use only dry powder fire extinguisher. Liquid extinguishers should not be used.
- Install the batteries only inside approved Fox enclosure. Installing the battery anywhere outside is strictly forbidden.
- Do not install the battery near water sources or places where the battery can get wet.
- Install the battery away from children or pets.
- Do not use battery in high static environment where the protection device might be damaged.
- Do not install with other batteries or cells.

## 4. Response to Emergency Situations

The batteries comprise of multiple batteries connected in series. It is designed to prevent hazards or failures. However, Fox cannot guarantee their absolute safety.

Under exposure to the internal materials of the battery the following recommendations should be carried out by the user.

- If there has been inhalation, please leave the contaminated area immediately and seek medical attention.
- If there has been contact with eyes, rinse the eyes with running water for 15 minutes and seek medical attention immediately.
- If there has been contact with the skin, wash the contacted area with soap thoroughly and seek medical attention immediately.
- If there has been ingestion, induce vomiting and seek medical attention.

### Fire Situation

In situations where the battery is on fire, if it is safe to do so, disconnect the battery pack by turning of the circuit breaker to shut off the power to the system. Use FM-200 or Co2 fire extinguisher for the battery and an ABC fire extinguisher for the other parts of the system.

Under any fire situation, please evacuate the people from the building immediately before trying to extinguish it.

### Water Situation

The battery modules are not water resistant. Hence care should be taken not to get it wet. If you find the battery completely or partially submerged in water do not try to open. Contact an authorized personnel or Fox for further instructions.

### 4.1 Warning Labels

Warning labels and other relevant labels are attached on the battery pack.

Rechargeable Li-ion Battery System		Model No./Nominal Voltage/Rated Capacity	
Product Name:	HS series	<input type="checkbox"/> HS 5.2/102.4Vdc/5.12kWh	IFP40214906(1165) 29(M)-2015095
Rated Capacity:	50Ah	<input type="checkbox"/> HS 7.8/153.6Vdc/7.68kWh	IFP40214906(1165) 39(M)-2015095
Ingress Protection:	IP21	<input type="checkbox"/> HS 10.4/204.8Vdc/10.24kWh	IFP40214906(1165) 49(M)-2015095
Protective Class:	I	<input type="checkbox"/> HS 13/256Vdc/12.8kWh	IFP40214906(1165) 59(M)-2015095
Operating Temperature:	-10-50°C	<input type="checkbox"/> HS 15.6/307.2Vdc/15.36kWh	IFP40214906(1165) 69(M)-2015095
Storage Temperature:	-20-50°C	<input type="checkbox"/> HS 18.2/358.4Vdc/17.92kWh	IFP40214906(1165) 79(M)-2015095
		<input type="checkbox"/> HS 20.8/409.2Vdc/20.48kWh	IFP40214906(1165) 89(M)-2015095

-Do not disassemble the battery pack      -Do not short-circuit the battery  
 -Do not immerse the battery pack in water      -Do not leave the battery near by fire  
**CAUTION** -The battery should be disposed by qualified recycling agent

**Emergency Situations**      \* If leaking, fire, wet or damaged, switch off the breaker and go away from the battery.  
 \* Do not touch the leaking liquid, Do not use water, sand or dry powder extinguisher is usable

**Manufacture:** FOXESS CO., LTD. **Factory:** FOXESS CO., LTD. WUXI BRANCH Made in China 10-200-20048-01

Lithium ion Battery Module	
Model No.:	HV2600
Nominal Capacity:	50Ah
Nominal Energy:	2.56kWh
Nominal Voltage:	51.2V
Voltage range:	40-58.4V
Max.charge/ discharge Current:	50A/50A
Ingress Protection:	IP21
Protective Class:	I
Operating Temperature:	-10-50°C
Storage Temperature:	-20-50°C

DANGER/ HIGH VOLTAGE

**Manufacture:** FOXESS CO., LTD.  
**Factory:** FOXESS CO., LTD. WUXI BRANCH  
 Made in China 10-200-20029-04

## 5. Product Information

1. HV2600 is a battery module, it needs to be used with BMS BOX controller;
2. BMS BOX is the controller of the whole system, so each system must have one BMS BOX;
3. Our system consists of at least 2 HV2600 + 1 BMS BOX and up to 8 HV2600 + 1 BMS BOX.

### 5.1 Battery Module Specifications

Specifications for HV2600	
Battery module	HV2600
Nominal capacity (kWh)	2.6
Maximum charge voltage (V)	58.4
Discharge cut voltage (V)	40
Max. charge/discharge current (A)	50A/50A
Operating temperature (°C)	-10 ~ 50
Storage temperature (°C)	-20 ~50
Charge/Discharge efficiency (%)	>98
Ingress protection	IP21
Protective class	I
Cycle life	>6000 @25°C @90% DOD
Available SOC range	10%~100%
Weight (kg)	29.7±1 kg
Dimensions (L*W*H) (mm)	420*480*116

### 5.2 BMS Specifications

Specifications for BMS BOX	
Model NO.	BMS-BOX
Operating voltage range(V)	60-500VDC
Max. charge/discharge current (A)	50A/50A
Total voltage measurement accuracy	±1.0%FSR
Total voltage measurement channel	2
Current measurement range	-65A~+65A
Insulation measurement accuracy	±5%@≤100KΩ
Communication interfaces	RS485/CAN
Available SOC range	10%~100%
Charge/Discharge efficiency (%)	>98
Operating temperature (°C)	-10 ~ 50
Storage temperature (°C)	-20 ~50
Humidity	10%~90%
Weight (kg)	4.5±1 kg
Dimensions (L*W*H) (mm)	443*410*116

### 5.3 Battery System Specifications

Specifications for Battery System							
The number of batteries	2*HV2600	3*HV2600	4*HV2600	5*HV2600	6*HV2600	7*HV2600	8*HV2600
Normal voltage(V)	102.4	153.6	204.8	256	307.2	358.4	409.6
Normal capacity (Ah)	50	50	50	50	50	50	50
Voltage range(V)	80-116.8	120-175.2	160-233.6	200-292	240-350.4	280-408.8	320-467.2
Recommended charging current(A)	25						
Max. charge/discharge current (A)	50						
CC-CV charging cut-off current(A)	2.5						
Peak charge current(A)(30s)	60						
Peak discharge current(A)	60						
Operating temperature (°C)	Charge: 0°C ~50°C Discharge: -10°C ~50°C						
Storage temperature (°C)	-20°C ~50°C						
Discharge capacity (Ah)	0±2°C @1C @80% 25±2°C @1C @100% 45±2°C @1C @96%						
Cycle life	≥6000 @25°C @ 90%DOD						
Ingress protection	IP21(Indoor)/IP65(Outdoor)			IP21			
Protective class	I						
Communication interfaces	RS485/CAN						
Weight (kg)	69.1±1kg (Net) 72.3±1 kg(Gross)	103.7±1kg (Net) 108.5±1 kg (Gross)	138.2±1kg (Net) 144.6±1 kg (Gross)	172.8±1kg (Net) 180.8±1 kg (Gross)	207.3±1kg (Net) 216.9±1 kg (Gross)	241.9±1kg (Net) 253.1±1 kg (Gross)	276.4±1kg (Net) 289.2±1 kg (Gross)

## 6. Product Features

### 6.1 Battery System Features

The batteries have been fitted with multiple protection systems to ensure the safe operation of the system. Some of the protection system includes:

- Inverter interface protection: Over voltage, Over current, External Short Circuit, Reverse Polarity, Ground Fault, Over Temp, In rush current
- Battery Protection: Internal Short Circuit, Over voltage, over current, over temp, Under voltage

The battery system contains the following Interface to allow it to connect and operate efficiently.

#### HV2600 Features:

- interface:

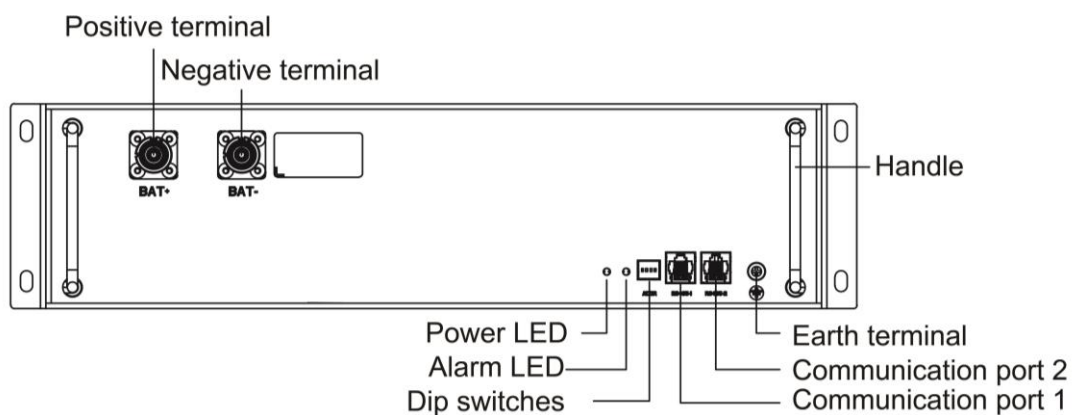

#### Power LED

This LED is used to indicate if the battery is operating effectively. A green light on this LED means the battery is ON and operating normally.

#### Alarm LED

This LED is used to indicate if the battery is operating failure. A red light on this LED means the battery is operating abnormally.

#### Communication Port A(RS485-1) and B(RS485-2)

HV2600 has two 485 communication units in series operation, one for master control and one for slave control.

Network interface description: RS485-1 is connected to the upper battery module, RS485-2 is connected to the lower battery module.

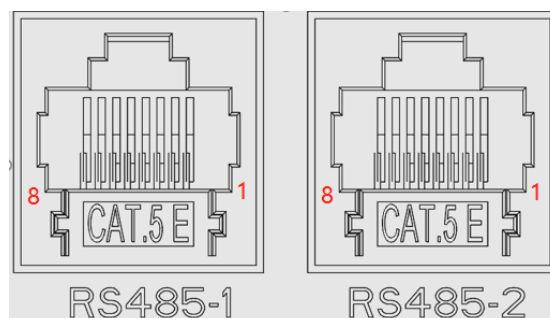



Pin configuration is as follows:

**- RS485-1**

Pin	Function Definitions	Function Declaration
1	GND	Power/signal ground
2	GND	Power/signal ground
3	B2	RS485-B
4	A2	RS485-A
5	VCC_485_2	Wake up the power supply+5v
6	P+	Signal P+
7	N-	Signal N-
8	VCC_485	power supply+5v

**- RS485-2**

Pin	Function Definitions	Function Declaration
1	GND	Power/signal ground
2	GND	Power/signal ground
3	B2	RS485-B
4	A2	RS485-A
5	VCC_485_2	Wake up the power supply+5v
6	P+	Signal P+
7	N-	Signal N-
8	VCC_485_NEXT	power supply+5v

**Earth Terminal**

This terminal is used to connect the battery to the earth for safety purposes.

**Handle**

The handle is used to push or pull the battery from its compartment. DO NOT LIFT THE BATTERY USING THIS HANDLE.

**Power Terminal**

A set of positive and negative terminals to connect the battery to the inverter. When you are unplugging the wires from the terminals, make sure you press the lock button and then pull it. When installing the plug, do not press the button and push the plug until you hear a click sound.

In addition to the above physical features, the battery has the following performance:

1. 90% Depth of Discharge
2. Cycle life >6000 cycles

**BMS BOX Features:**

- interface

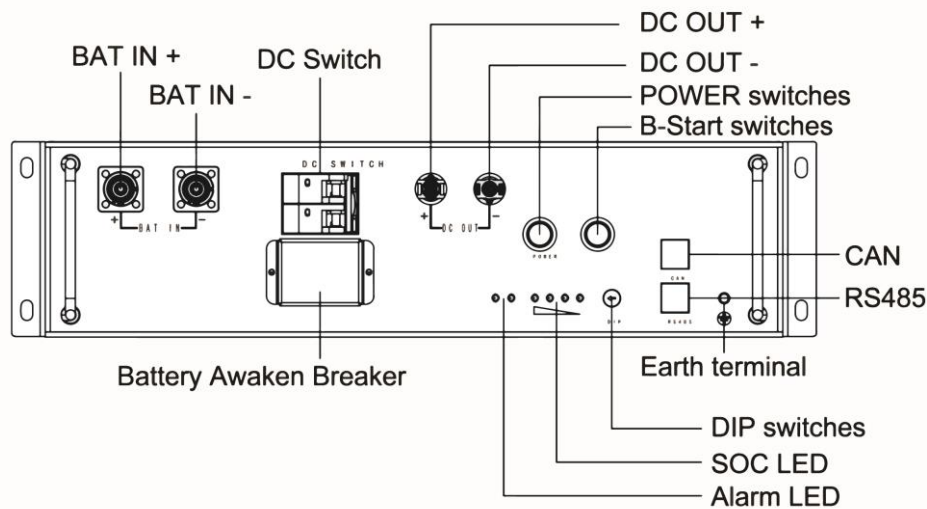

**BAT IN +**

Positive electrode of battery.

**BAT IN -**

Negative electrode of battery.

**DC switch**

Power switch, battery charge and discharge circuit switch.

**DC OUT +**

Connect bat + of inverter.

**DC OUT -**

Connect bat - of inverter.

**POWER switches**

System power on switch, press this switch, the system starts to work.

**B-Start switches**

Black start switches, if you want to start the battery system when there is no grid, press this switch first and then power on the system.

**DIP switches**

BMS relies on DIP switches to confirm the number of HV2600 in the system.

**SOC LED**

LED display battery system power and specific alarm information.

**Alarm LED**

If there is a fault in the system, the LED will display.

**Battery Awaken Breaker**

For maintenance only, please do not open the metal cover without authorization. Please contact service department for further operation on this breaker. Only Fox unauthorized personnel are allowed to dismantle it.

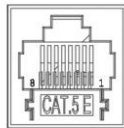
**CAN & RS485 communication**

CAN

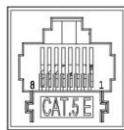

RS485

**- CAN**

Pin	Function Definitions	Function Declaration
1	NC	
2	GND	Power/signal ground
3	B1	RS485-B
4	CANL	CANL
5	CANH	CANH
6	NC	
7	NC	
8	A1	RS485-A

**- RS485**

Pin	Function Definitions	Function Declaration
1	GND	Power/signal ground
2	GND	Power/signal ground
3	P+	Signal P+
4	VCC_485_2	Wake up the power supply+5v
5	N-	Signal N-
6	B2	RS485-B
7	A2	RS485-A
8	VCC_485	power supply+5v

**Earth Terminal**

This terminal is used to connect the battery to the earth for safety purposes.

## 7. Installation

### 7.1 Items in the package

Please check if following items are including with the package:

For HV2600

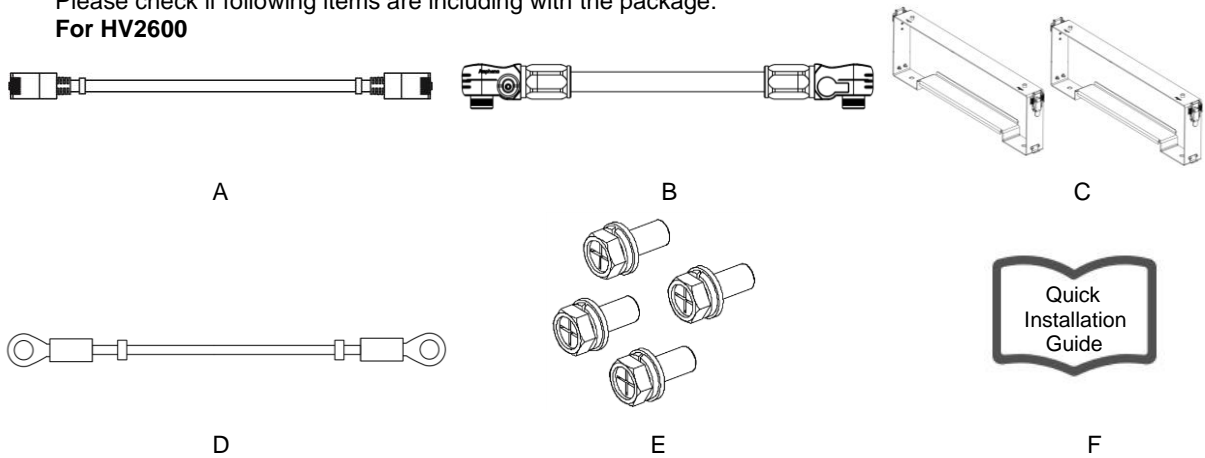

Number	Items	Number	Items
A	Communication cable (0.21m)	D	Grounding cable (0.19m)
B	Battery power cable (0.19m)	E	Mounting screw pack
C	Fixing bracket	F	Installation guide

Note: item C is provide separately, not including in battery package. Please contact your dealer if you do not have it.

For BMS BOX

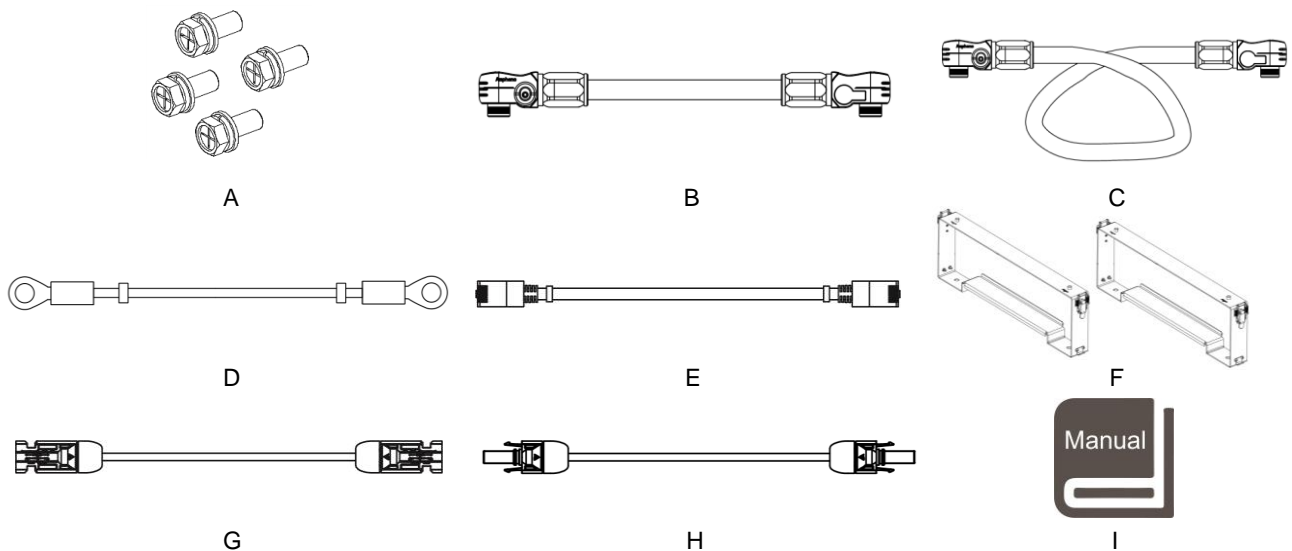

Number	Items	Number	Items
A	Mounting screw pack	F	Fixing bracket
B	Main negative battery connection cable (0.17m)	G	DC negative output cable (1.2m)
C	Main positive battery connection cable (1.3m)	H	DC positive output cable (1.2m)
D	Grounding cable (1m)	I	User manual
E	Communication cable (BMS-inverter) (1.2m)		

Note: item H is provide separately, not including in battery package. Please contact your dealer if you do not have it.

## 7.2 Clearance

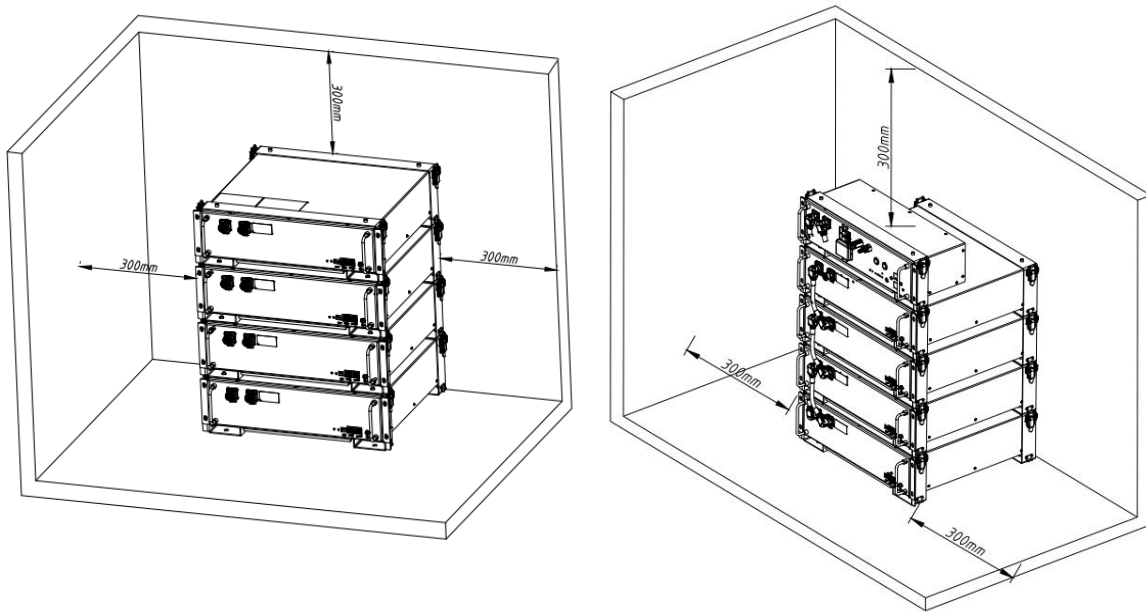

Make sure to leave a space of at least 300 mm. A clearance of at least 300 mm must be left around the battery pack for proper cooling.

Note: Make sure that the battery pack is always exposed to the ambient air. The battery pack is cooled by natural convection. If the battery pack is entirely or partially covered or shielded, it may cause the battery pack to stop operating.

## 7.3 Tools

The following tools will be required to install the BMS BOX and the battery.



Screw Driver



Crimping Modular



Safety Shoes



Multimeter



Safety Gloves



Safety Goggles



Plier



Ribbon

## 7.4 Installation Steps

Step 1: Place the front bracket and back bracket as shown below.

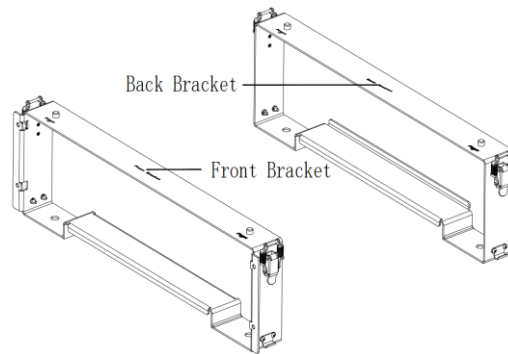

Step 2: Insert the battery module into the bracket from front horizontally, and tighten the four screws on the side.

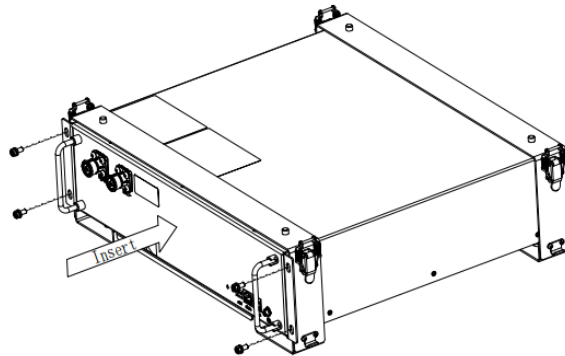

Step 3: Locate the brackets for the second battery on top of the first pair of the bracket and fasten the connecting button on the side.

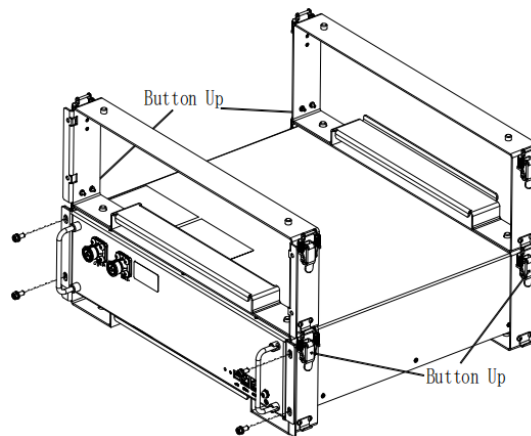

Step 4: Insert the battery module into the bracket from front horizontally, and tighten the four screws on the side.

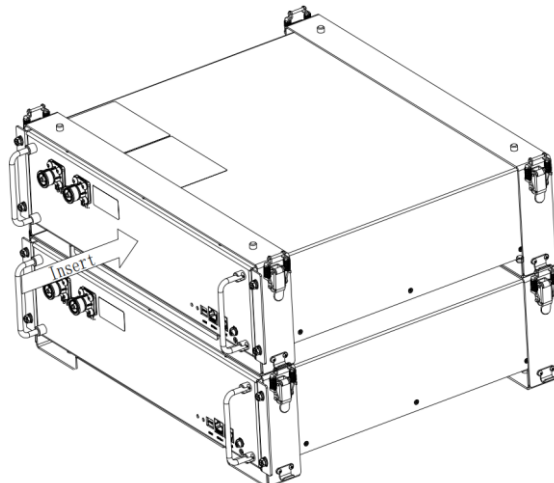

Step 5: Connect the inverter as shown in the figure below.

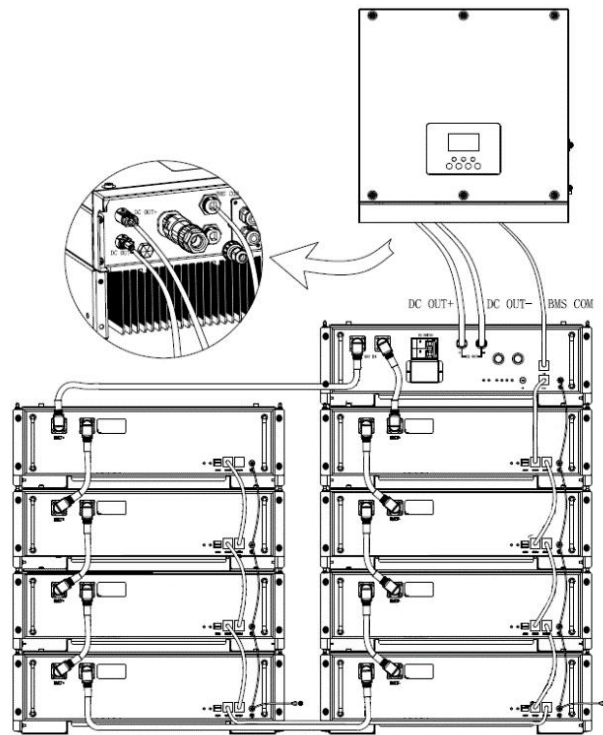

Note: If the Battery modules are more than 4 pieces, please separate into multiple stacks. Please make sure each stack only including max. 1 BMS and 4 battery modules.

**Battery modules less than 4 pieces:**

**Battery modules more than 4 pieces:**

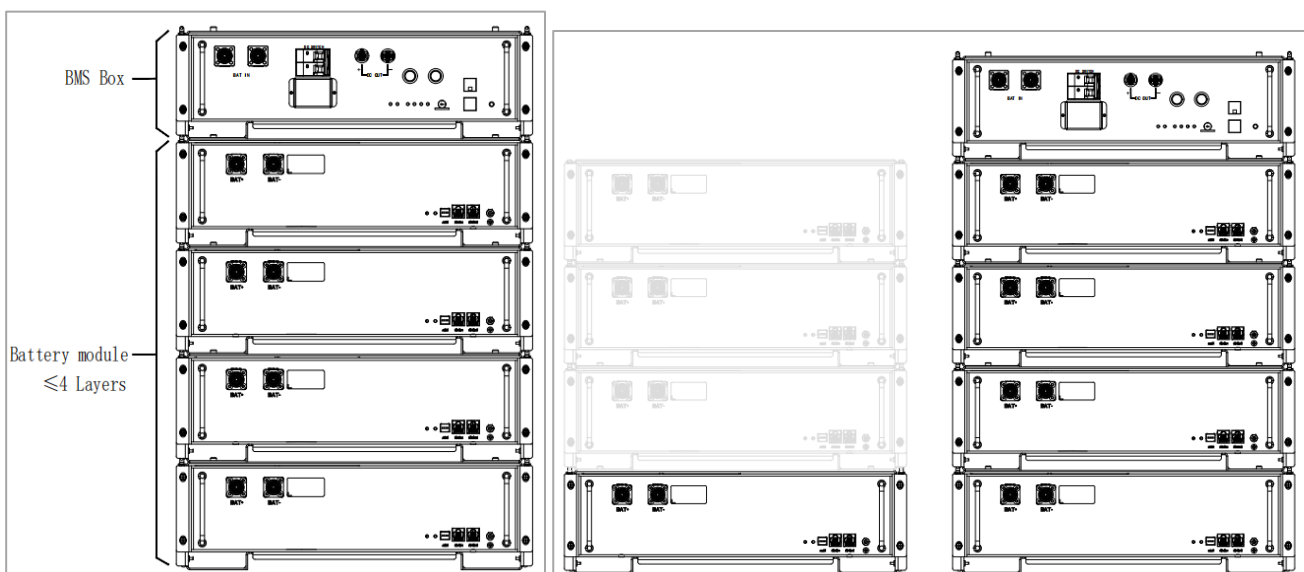

Note: For another installation, please refer to the All-In-One user manual.

## 7.5 Wiring Steps

### A. Battery power cable

**Step 1:** Connect the power cable starting from the first battery module in series with other battery modules (Orange opposite, black negative). A 'click' sound indicates the connections are secured. The positive and negative connection of the battery cable is shown in below.

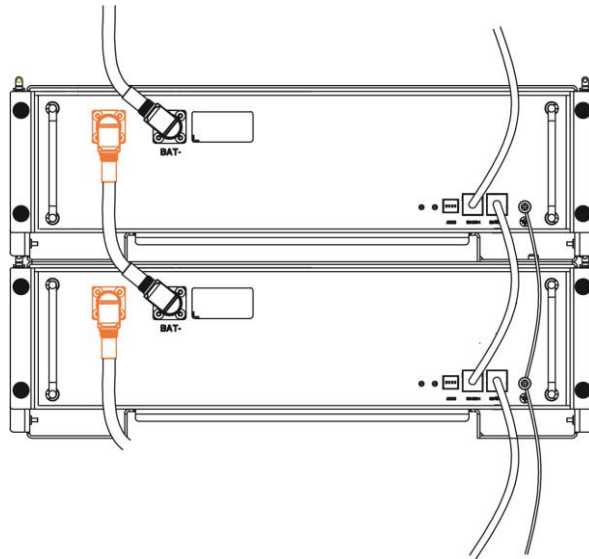

**Step 2:** Measure voltage value: After all battery modules are connected in series, use a multimeter to measure the DC voltage on DC terminal. The total voltage should be  $N * 52 \pm 10V$  (N is the total number of battery module). Please refer to the picture below for voltage test.

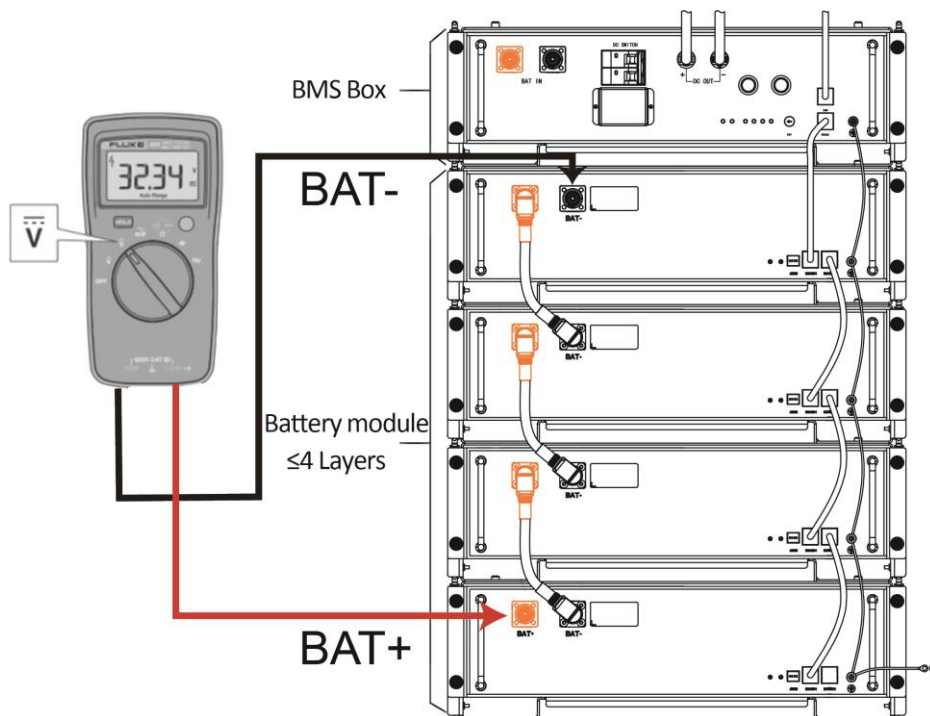

### B. Communication cable connection:

**Step 1:** Take the main positive cable (two orange plugs), the main negative line (two black plugs) to connect the BMS BOX.

**Step 2:** Then connect the 485 on the BMS BOX to the RS485-1 of the first battery module, connect the RS485-1 of the previous battery module to RS485-2 of the next battery module, leave the last module's RS485-2 vacant. Wiring shall be connected in the sequence as shown in below.

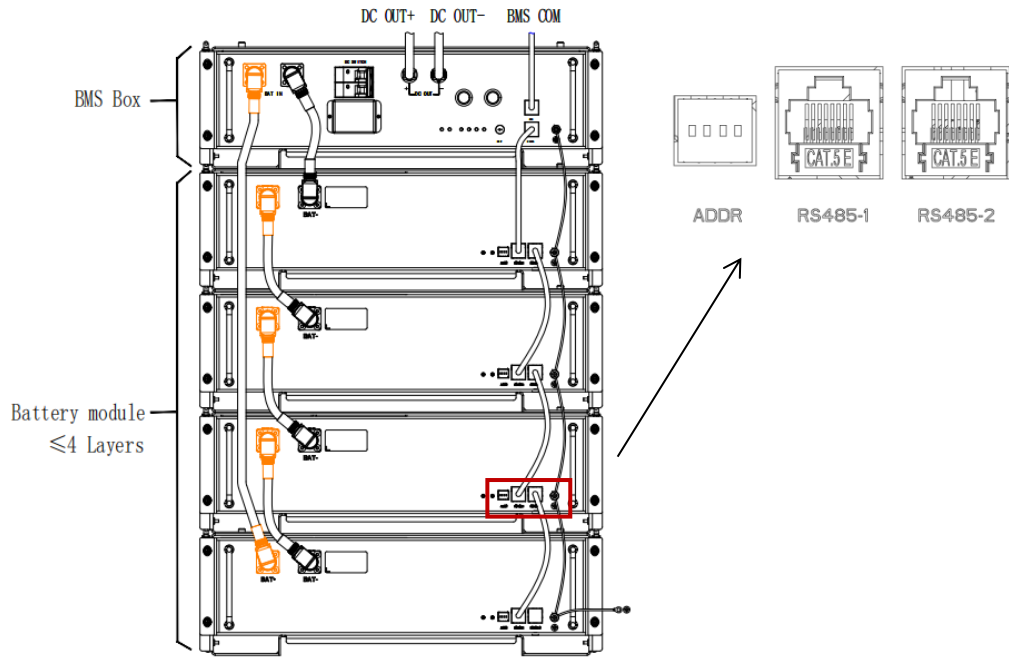

### C. Grounding cable:

Connect the grounding cable to ensure that all batteries are grounded. Wiring shall be connected in the sequence as shown in below.

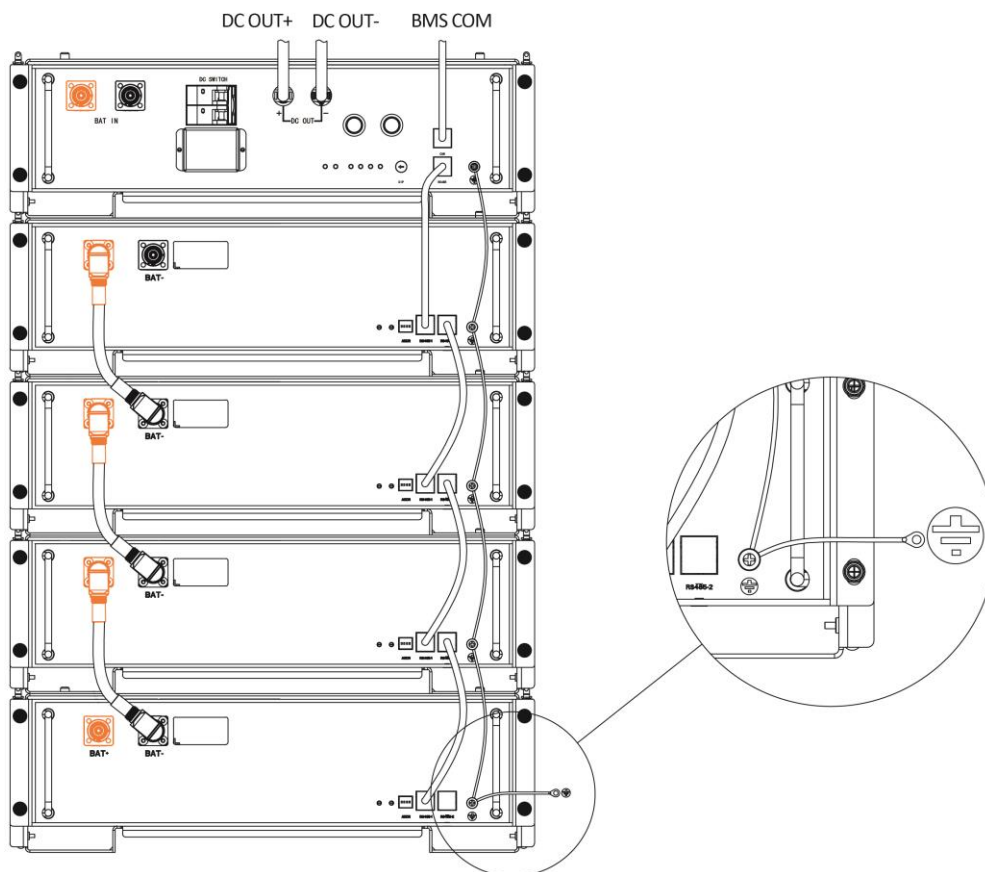



## 7.6 System Start up

- When the grid connected system is started, the inverter should be turned on first to avoid the current pulse of the inverter increasing to the battery pack.
- All installation and operation must comply with local electrical standards.
- Check all power cables and communication cables carefully.

### 1. Turn on the POWER switch

- Before starting, please dial DIP to the correct position. DIP represents the number of HV2600 in the system. Please refer to the following table for details:

DIP position	The number of HV2600
0	2
1	3
2	4
3	5
4	6
5	7
6	8

- Turn on DC switch and press the POWER switch, all the light will light up, and the green and red LED on the HV2600 module will light up for 1s at the same time, you will hear the sound of closing and cutting off the relay in BMS BOX to prove that the system works normally.

### 2. Module address assignment

If the system is powered on for the first time, BMS will automatically assign the module address of HV2600 without manual configuration.

## 8. Commissioning

There are two LED indicators on the front of the battery packs to show its operating status.

### For HV2600





















Green LED	Red LED	Batteries Status
On for 1s	On for 1s	Initial power on
On for 4s	Off	Work
Off	On	Communication lost
On for 4s	On for 4s	Recoverable alarm
Off	On for 4s	Unrecoverable Alarm

### For BMS-BOX





- Alarm LED

BMS-BOX Condition	Green	Red
Error	Off	Flash
Standby	Flash	Off
Charge/Discharge	On	Off

- SOC LED indication

Status		Charge	Discharge	Stand By
=100%		On	On	Off
		On	On	
		On	On	
		On	On	
>100%>soc>=75%		Flash	On	
		On	On	
		On	On	
		On	On	
75%>soc>=50%		Off	Off	
		Flash	On	
		On	On	
		On	On	
50%>soc>=25%		Off	Off	
		Off	Off	
		Flash	On	
		On	On	
25%>soc>=0		Off	Off	
		Off	Off	
		Off	Off	
		Off	On	

- SOC LED fault message

Fault				
Differential pressure fault	Off	Off	Off	Flash
Under voltage fault	Off	Off	Flash	Off
Over temperature fault	Off	Off	Flash	Flash
Under temperature fault	Off	Flash	Off	Off
Discharge over current	Off	Flash	Off	Flash
Charge over current	Off	Flash	Flash	Off
Over voltage fault	Off	Flash	Flash	Flash
MCU fault	Flash	Off	Off	Off
AFE fault	Flash	Off	Off	Flash
Disconnection fault	Flash	Off	Flash	Off
Current sensor failure	Flash	Off	Flash	Flash
Insulation failure	Flash	Flash	Off	Off
Temperature sensor failure	Flash	Flash	Off	Flash
Contactors failure	Flash	Flash	Flash	Off
Slave control lost fault	Flash	Flash	Flash	Flash

## 9. Exclusion

The warranty shall not cover the defects caused by normal wear and tear, inadequate maintenance, handling, storage faulty repair, modifications to the battery or pack by a third party other than Fox or Fox agent, failure to observe the product specification provided herein or improper use or installation, including but not limited to the following.

- Damage during transport or storage.
- Incorrect Installation of battery into pack or maintenance.
- Use of battery or pack in inappropriate environment.
- Improper, inadequate, or incorrect charge, discharge or production circuit other than stipulated herein.
- Incorrect use or inappropriate use.
- Insufficient ventilation.
- Ignoring applicable safety warnings and instructions.
- Altering or attempted repairs by unauthorized personnel.
- In case of force majeure (ex: lightning, storm, flood, fire, earthquake, etc.).
- There are no warranties-implicit or express-other than those stipulated herein. Fox shall not be liable for any consequential or indirect damages arising or in connection with the product specification, battery or pack.

## 10. Troubleshooting and Maintenance

### 10.1 Maintenance

- A. Regularly check whether the service environment of the battery meets the requirements, and the installation position should be far away from the heat source.
- B. In case of one of the following situations, it needs to be charged in time:
  - The battery is often under charged;
  - The battery has been out of use or stored for more than 3 months.
- C. Regularly check whether the battery and its supporting terminals, connecting cables and indicator lights are normal.

### 10.2 Troubleshooting

When the red / green LED on the panel is flashing or normally on, it does not mean that the HV2600 is abnormal, it may be just an alarm or protection. Please check the 'LED status indicators' in chapter 7 for the detailed faulty definition before any trouble-shooting steps. In general, the alarm indication is normal without manual intervention. When the alarm triggering state is removed, HV2600 will automatically return to normal use.

#### - Problem determination based on the following points

- 1) Whether the green light on the power switch is on;
- 2) Whether the buzzer in BMS box on;
- 3) Whether the battery system can be communicated with inverter;
- 4) Whether the battery can be output voltage or not.

#### - Preliminary determination steps

Battery system cannot work, when DC switch on and POWER on, the LED doesn't light up or flash, please consider contact the local distributor.

- 1) The LED display of BMS-BOX and HV2600 is normal, but it cannot charge and discharge. Observe the display screen of inverter and there is no SOC. Please check whether the CAN communication between BMS-BOX to inverter is well connected. If the connection is good, please replace a CAN communication cable. If the SOC is still not visible on the inverter display screen, please contact the local distributor.
- 2) After the battery system is powered on, if you can see the alarm information on the LED and inverter display screen at the same time, please contact the local distributor.

The copyright of this manual belongs to FOXESS CO., LTD WUXI BRANCH. Any corporation or individual should not plagiarize, partially or fully copy (including software, etc.), and no reproduction or distribution of it in any form or by any means is permitted. All rights reserved.

FOXESS CO., LTD WUXI BRANCH

Add: No.11, Lijiang Road, Xinwu District, Wuxi City,  
Jiangsu Province, China  
Tel: 0510- 68092998  
WWW.FOX-ESS.COM.